

Lavastoviglie a cesto trascinato compatte Compact Rack Type dishwasher

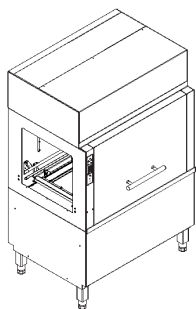

RTCS90 / WTCS90

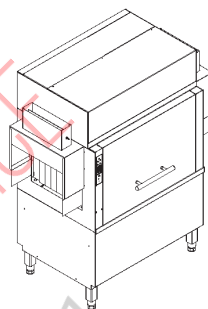

RTCS140 / WTCS140

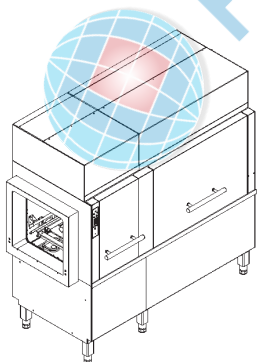

RTCS180 / WTCS180

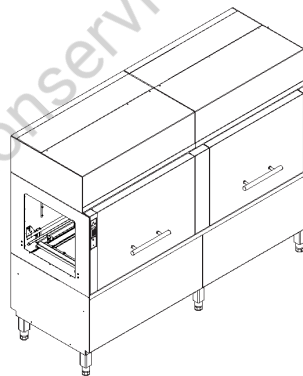

RTCS250 / WTCS250

Marchio/Brand: **E**
Paese/Country: **Tutti/All**

Da Ser.Nr./From Ser.nr.: 811

Page: 1 Ed. 2016-10

Doc. Nr.: **595664900**

(6-57001)

INDICE / INDEX

Disegno/ Drawing	Descrizione / Description	Pagina/ Page
	PROSPETTO COMPOSIZIONE MODULI / VIEW OF MODULE COMPOSITION	3
ill. 657001p1	Lavaggio + Risciacquo da 44", vista generale / Wash + Rinse from 44", Main view	4
	Lista ricambi / Spare parts list	5
ill. 657001p2	Prelavaggio da 22", vista generale / Prewash from 22", Main view	8
	Lista ricambi / Spare parts list	9
ill. 657001p3	Prelavaggio da 44", vista generale / Prewash from 44", Main view	11
	Lista ricambi / Spare parts list	12
ill. 657001p4	Lavaggio+Risciacquo da 44", Circuito Idraulico lavaggio/ Wash+Rinse from 44", Wash hydraulic circuit	14
	Lista ricambi / Spare parts list	15
ill. 657001p5	Lavaggio+Risciacquo da 44", Circuito Idraulico a pressione risciacquo/ Wash+Rinse from 44", Rinse pressure hydraulic circuit	17
	Lista ricambi / Spare parts list	18
ill. 657001p6	Prelavaggio da 22", Circuito Idraulico / Prewash from 22", Hydraulic circuit	20
	Lista ricambi / Spare parts list	21
ill. 657001p7	Prelavaggio da 44", Circuito Idraulico / Prewash from 44", Hydraulic circuit	23
	Lista ricambi / Spare parts list	24
ill. 657001p8	Lavaggio+Risciacquo da 44", Componenti elettrici / Wash+Rinse from 44", Electrical components	26
	Lista ricambi / Spare parts list	27
ill. 657001p9	Prelavaggio da 22", Componenti elettrici / Prewash from 22", Electrical components	30
	Lista ricambi / Spare parts list	31
ill. 657001p10	Prelavaggio da 44", Componenti elettrici / Prewash from 44", Electrical components	32
	Lista ricambi / Spare parts list	33
ill. 657001p11	Kit Air gap (Only for Middle East version - WTCS140XXO/ WTCS180XXO)	35
	Lista ricambi / Spare parts list	36

Da Ser.Nr./From Ser.nr.: 811

Page: 2 Ed. 2011-12

Doc. Nr.: **595664900**

(6-57001)

PROSPETTO COMPOSIZIONE MODULI / VIEW OF MODULE COMPOSITION

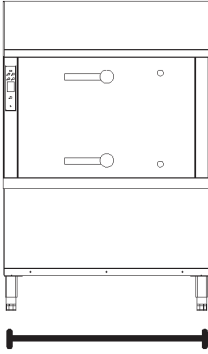
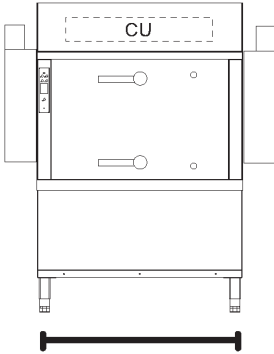
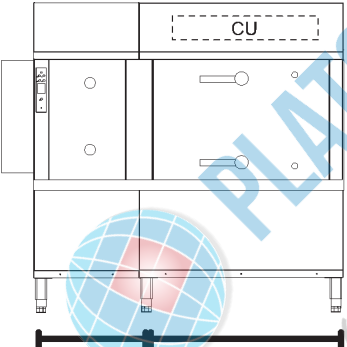
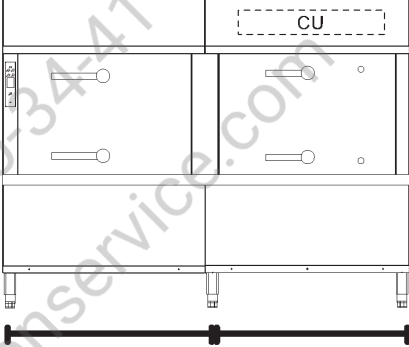
RTC90 / WTC90	RTC140 / WTC140
 <p data-bbox="395 674 608 719">Lavaggio + Risciacquo / Wash + Rinse (44")</p>	 <p data-bbox="986 674 1198 719">Lavaggio + Risciacquo / Wash + Rinse (44")</p>
<p data-bbox="411 763 592 853">ill. 657001p1 pag. 4 ill. 657001p4 pag. 14 ill. 657001p5 pag. 17 ill. 657001p8 pag. 26</p>	<p data-bbox="1002 763 1182 853">ill. 657001p1 pag. 4 ill. 657001p4 pag. 14 ill. 657001p5 pag. 17 ill. 657001p8 pag. 26</p>
RTC180 / WTC180	RTC250 / WTC250
 <p data-bbox="347 1301 687 1346">Prelavaggio / Lavaggio + Risciacquo / Prewash (22") Wash + Rinse (44")</p>	 <p data-bbox="906 1301 1289 1346">Prelavaggio / Lavaggio + Risciacquo / Prewash (44") Wash + Rinse (44")</p>
<p data-bbox="268 1397 448 1464">ill. 657001p2 pag. 8 ill. 657001p7 pag. 23 ill. 657001p9 pag. 30</p> <p data-bbox="560 1397 740 1487">ill. 657001p1 pag. 4 ill. 657001p4 pag. 14 ill. 657001p5 pag. 17 ill. 657001p8 pag. 26</p>	<p data-bbox="852 1397 1032 1464">ill. 657001p3 pag. 11 ill. 657001p7 pag. 23 ill. 657001p9 pag. 30</p> <p data-bbox="1145 1397 1326 1487">ill. 657001p1 pag. 4 ill. 657001p4 pag. 14 ill. 657001p5 pag. 17 ill. 657001p8 pag. 26</p>

Da Ser.Nr./From Ser.nr.: 811

Page: 3 Ed.2008-09

Doc. Nr.: 595664900

(6-57001)

??????	534304										
??????	595664900	???????? 4							Wash + Rinse from 44", Main view		
.		Alias		S			.				(Euro)
0101	000000	83065GC00								From Ser.: 5151	
0101	0L1723	830654B00							COVER PLATE; ASSY; 44" NEWRT	Up to Ser. Nr.: 908	251,70
0101	0L2041	830654B02							COVERING; ASSY; NEWRT	Up to Ser.: 5141	263,90
0101	0L2041	830654B03							COVERING; ASSY; NEWRT	From Ser. Nr.: 909	263,90
0102	0L1517	830652000							COVERING; COMPACT NEWRT	Up to Ser. Nr.: 908	296,40
0103	0L1721	830654A01							BACK PANEL; ASSY; 44" NEWRT	Up to Ser. Nr.: 908	278,10
0103	0L2040	830654A03							BACK PANEL; NEWRT	From Ser. Nr.: 909 - Up to Ser. Nr.: 146	272,00
0103	0L2542	830657Y00							BACK PANEL	From Ser. Nr.: 147	258,80
0105	0L0875	543629700							GASKET		19,43
0106	0L1584	830651401							SIDE PANEL; ASSY		76,94
0107	0L0877	800667301							PLUG; ASSY		35,02
0108	0L0876	543631001							GASKET		12,57
0109	0L1169	830643202							SUPPORT; FOR PANEL NEWRT		52,98
0110	0L0832	830637101		S					DOOR GUIDE; RH		91,65
0111	0L0833	830637201		S					DOOR GUIDE; LH		91,65
0112	0L0856	830641103							PANEL; SLIM		68,31
0113	0L1706	830654C01							PANEL; ASSY		71,66
0114	0L1510	835620901	0L2461						DOOR ASSEMBLY; 44" NEWRT	Up to Ser: 1450	
0114	0L2461	835621F00							DOOR ASSEMBLY; 44" ECOLAB NEWRT	From Ser: 1451	651,00
0115	0E2898	W00143601							SPRING RETAINER		14,89
0116	0L1492	5046A2301							SPLASH GUARD; NEWRT; DOOR 44"		22,43
0117	0L0839	549644800							PEG		2,84
0118	0L1722	503617D02							REAR PANEL; NEWRT	Up to Ser. Nr.: 146	200,00
0118	0L2628	503617D03							FRONT PANEL	From Ser. Nr.: 147	175,60
0119	0L1520	503613802							CRANKCASE; COMPACT NEWRT	Up to Ser.: 5141	72,17
0119	0L3562	5046ABB00							PROTECTION; NEWRT	From Ser.: 5151	56,84
0120	0L1314	5046A3800		S					TOOTH; DX		16,03
0121	0L1315	5046A3900		S					TOOTH; SX		16,03
0122	0L1303	830632401							FEEDING LADDER; M1165 NEW RT		263,90
0123	0L0827	543630300		S					GASKET		26,59
0124	0L0992	502697601							COVERING; NEWRT		36,24
0125	0L0991	502697501							COVERING		25,78
0126	0L0852	800667800							SUPPORT; SINGLE SHORT CURTAIN		37,86
0127	0L0853	503603601							FOOT WITH FRAME		110,60
0128	0L2443	W00017300		S					ROLLER; Ø=40MM; H=16MM; WHITE	Up to Ser. Nr.: 146	5,81
0128	0L2520	547604800		S					ROLLER	From Ser. Nr.: 147	6,02

??????	534304									
??????	595664900	???????? 4					Wash + Rinse from 44", Main view			
.		Alias		S			.			(Euro)
0129	0L2174	549646100		S			WASHER	From Ser. Nr.: 147		1,58
0129	0L2174	549646100		S			WASHER	Up to Ser. Nr.: 146		1,58
0130	0L2515	5146A4100		S			PROTECTIVE GRATING	From Ser. Nr.: 147		19,79
0131	0L2167	543633J00					GASKET			30,45
0132	0L1732	541617000		S			CURTAIN; DOUBLE; 580X490MM; PVC			114,70
0133	0L1768	800667600					SUPPORT			44,96
0134	0E5826	RT0003700		S			CURTAIN AXIS; L=580 MM			16,80
0135	0L1172	505600001					HOOK; FOR CURTAIN NEWRT			15,10
0136	0L1733	541617100		S			CURTAIN; SINGLE; PVC			67,09
0137	0L2522	219614400		S			SNAP RING	From Ser. Nr.: 147		1,02
0138	0L2521	5066A0R00		S			DISC	From Ser. Nr.: 147		4,44
0140	0L0857	515659300		S			ROLL			6,12
0141	0L1170	546631100		S			BUSHING; FOR SPRING NEWRT			7,18
0142	0E5167	W00093300					SPRING BLADE; 38X0,5 MM			56,10
0143	0L1505	830646701	0L2590				BASKET GUIDE; 44"; COMPACT NEWRT	Up to Ser. Nr.: 146		
0143	0L2519	830657T00	0L2590				BASKET GUIDE	From Ser. Nr.: 147		
0143	0L2519	830657T00	0L2590				BASKET GUIDE	Up to Ser. Nr.: 1450		
0143	0L2590	835621U00					BASKET GUIDE; ASSY	Up to Ser. Nr.: 147		235,50
0143	0L2590	835621U01					BASKET GUIDE; ASSY	From Ser. Nr.: 1451		235,50
0143	0L3289	83065AN01					BASKET GUIDE; ASSY; LWC44	From Ser. Nr.: 1451		203,00
0144	0L1308	835620702		S		+	DRIVE AXIS; COMPACT NEWRT			139,10
0145	0L0861	541612801		S			DOOR CATCH			2,43
0146	0L1278	514695102		S			PIVOT; FOR BUSHING NEWRT			20,60
0147	0L0993	541612500					PLUG; PLASTIC			1,02
0148	0E5043	W00115100					FLANGED BUSH			9,29
0149	0L0847	514695001		S			ROD; GEAR MOTOR			125,90
0150	0L0997	RT0021201					SUPPORT; FOR CURTAIN	For 140 b/h		12,36
0151	0E5187	W00111300					RING			10,87
0152	0L0849	830640401	0L2317				SUPPORT; GEAR MOTOR	Up to Ser. Nr.: 928		91,86
0152	0L2091	504696302	0L2317				MOTOR BRACKET	From Ser. Nr.: 929 - Up to Ser. Nr.: 019		30,86
0152	0L2317	504696303					MOTOR BRACKET	From Ser. Nr.: 020		29,54
0153	0L0152	RT0020700		S			SPRING; MM.50X25,4X3,4H			4,50
0154	0L1713	548648J00					ADHESIVE MEMBRANE; NEUTRAL DX; 1 SPEED	Multibrand - 1 speed		72,47
0154	0L1714	548648K00					ADHESIVE MEMBRANE; NEUTRAL SX; 1 SPEED	Multibrand - 1 speed		72,47
0154	0L1715	548648L00					ADHESIVE MEMBRANE; NEUTRAL DX; 2 SPEED	Multibrand		72,47
0154	0L1716	548648M00					ADHESIVE MEMBRANE; NEUTRAL SX; 2 SPEED	Multibrand		72,47

??????	534304									
??????	595664900		???????? 4					Wash + Rinse from 44", Main view		
.		Alias		S			.			(Euro)
0154	0L1744	548649600						ADHESIVE MEMBRANE; LEFT; 1 SPEED	Electrolux - 1 speed	72,47
0154	0L1745	548649700						ADHESIVE MEMBRANE; RIGHT; 1 SPEED	Electrolux - 1 speed	72,47
0154	0L1746	548649800						ADHESIVE MEMBRANE; LEFT; 2 SPEED	Electrolux	64,76
0154	0L1747	548649900	0L3750					ADHESIVE MEMBRANE; RIGHT; 2 SPEED	Electrolux	64,76
0156	0L1717	548649100						ADHESIVE; COMPACT NEWRT	Zanussi	11,61
0156	0L1718	548649200						ADHESIVE; COMPACT NEWRT	Alpeninox	11,61
0160	0L1280	611634100		S	A			MOTOR; 110/190V 50HZ		268,00
0161	0L1281	835621300		S	A			GEARMOTOR		337,00
0162	0L1275	547604600		S				GLIDE SHOE; NEWRT		28,42
0163	0L1471	543631300		S				GASKET; NEWRT		13,62
0164	0L1470	502697402						BRACKET; FOR GASKET NEWRT		12,25
0165	0L1469	503609200						PLAQUE; FOR GASKET NEWRT		3,69
0166	0L1597	565615200		S	A			DOOR GASKET; NEWRT		1,68
0167	0L1712	5146A2500		S				NUT; M24		19,58
0168	0L1528	507690700		S				SPRING LATCH		11,41
0171	0L1770	830654L01						EXHAUST HOOD		185,70
0172	0L1583	805664300						SHUTTER; 44" COMPACT NEWRT		19,69
0173	0L1046	507689001						SUPPORT;BACKPANEL SUPPORT	From Ser. Nr.: 909 Up to Ser. Nr.: 928	16,26
0173	0L2088	805664Q00						SUPPORT; FOR BACK PANEL; NEWRT	From Ser. Nr.: 929	18,98
0179	049931	590603500						VELCRO; BY MT.	From Ser. Nr.: 147	6,45
0180	0L2554	569608F00						FOIL PROTECTION	From Ser. Nr.: 147	8,16
104a	0L0826	830638203						LEFT PANEL	Not for 140 b/h	187,80
104a	0L1726	8E+07						LEFT SIDE PANEL; NEWRT	For 140 b/h	198,90
104b	0L0880	830638303						PANEL; RH	Not for 140 b/h	187,80
104b	0L1725	830654D02						RIGHT SIDE PANEL; NEWRT	For 140 b/h	198,90
139a	0L1720	5026B8F00			D			LEFT SIDE; LOWER; NEWRT	From Ser: 1451	130,90
139b	0L1719	5026B8D00			D			RIGHT SIDE; LOWER; NEWRT	From Ser: 1451	130,90
155a	0L1181	5146A0500		S				PROTECTION; NEWRT	Up to Ser. Nr.: 146	25,68
155a	0L2514	5146A4F00						PROTECTION	From Ser. Nr.: 147	18,69
155b	0L2514	5146A4F00						PROTECTION	From Ser. Nr.: 147 - Only for machine with CU	18,69

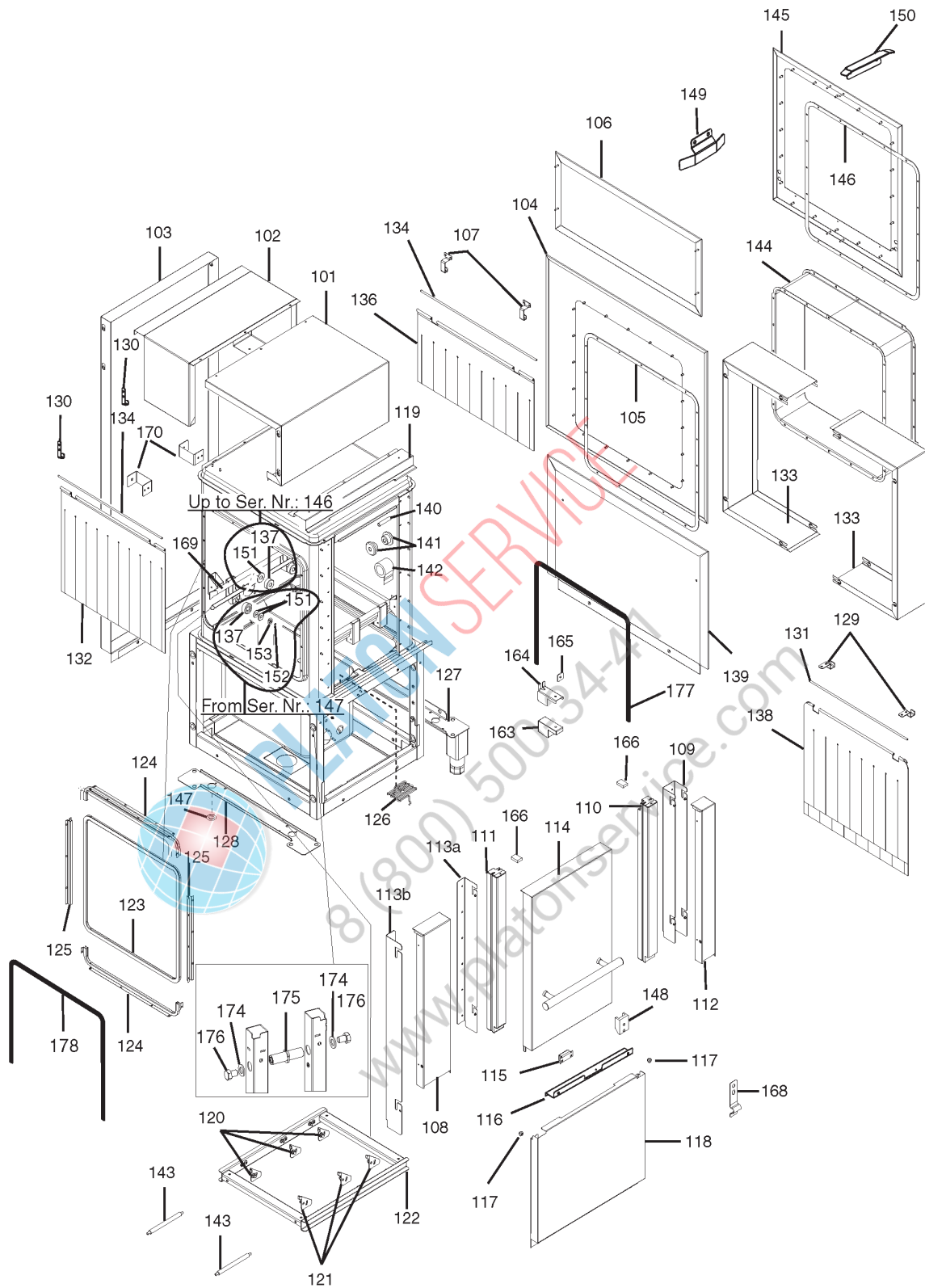

iii. 657001p2
 Prelavaggio da 22", vista generale / Prewash from 22", Main view

Da Ser.Nr./From Ser.nr.: 811 Page: 8 Ed.2012-11	Doc. Nr.: 595664900 (6-57001)
--	----------------------------------

??????		534304									
??????		595664900		????????? 8		Prewash from 22", Main view					
.		Alias		S							(Euro)
0101	0L1493	830652500						COVERING; COMPACT NEWRT; 22"	Up to Ser. Nr.: 908		127,90
0101	0L2042	830654Z01						COVERING; ASSY; NEWRT	From Ser. Nr.: 909		149,20
0102	0L1586	830651900						COVERING; ASSY; 22"	Up to Ser. Nr.: 908		133,00
0103	0L1522	830653301						BACK PANEL; COMPACT NEWRT	Up to Ser. Nr.: 908		215,20
0103	0L2043	830654X01						BACK PANEL; ASSY; NEWRT	From Ser. Nr.: 909 - Up to Ser. Nr.: 146		208,10
0103	0L2541	830657X00						BACK PANEL	From Ser. Nr.: 147		207,10
0104	0L0976	830636803						PANEL; ASSY			168,50
0104	0L1179	830636603						PANEL; ASSY INT.			168,50
0105	0L0875	543629700						GASKET			19,43
0106	0L1584	830651401						SIDE PANEL; ASSY			76,94
0107	0L1172	505600001						HOOK; FOR CURTAIN NEWRT			15,10
0108	0L0984	830641003						PANEL			80,49
0109	0L1169	830643202						SUPPORT; FOR PANEL NEWRT			52,98
0110	0L0832	830637101		S				DOOR GUIDE; RH			91,65
0111	0L0833	830637201		S				DOOR GUIDE; LH			91,65
0112	0L0856	830641103						PANEL; SLIM			68,31
0114	0L1509	835620801	0L2462					DOOR ASSEMBLY; 22" NEWRT	Up to Ser: 1450		
0114	0L2462	835621N00		D				DOOR ASSEMBLY; 22" ECOLAB USA NEWRT	From Ser: 1451		502,00
0115	0E2898	W00143601						SPRING RETAINER			14,89
0116	0L1491	5046A2201						SPLASH GUARD; NEWRT; DOOR 22"			19,54
0117	0L0839	549644800						PEG			2,84
0118	0L1523	503613201						FRONT PANEL; COMPACT NEWRT			95,41
0119	0L1524	503613702						CRANKCASE; COMPACT NEWRT			50,75
0120	0L1314	5046A3800		S				TOOTH; DX			16,03
0121	0L1315	5046A3900		S				TOOTH; SX			16,03
0122	0L1305	830636905						FEEDING LADDER; M600 PREWASH NEWRT			263,90
0123	0L0827	543630300		S				GASKET			26,59
0124	0L0992	502697601						COVERING; NEWRT			36,24
0125	0L0991	502697501						COVERING			25,78
0126	0L2515	5146A4100		S				PROTECTIVE GRATING	From Ser. Nr.: 147		19,79
0127	0L0853	503603601						FOOT WITH FRAME			110,60
0128	0L0854	502696002						SUPPORT; FEET SUPPORT NEWRT			35,73
0129	0L0898	506600400						HOOK			12,62
0130	0L1171	503610500						HOOK; NEWRT			15,52
0131	0L0873	514699200						CURTAIN AXIS; L=490			15,86
0132	0L1732	541617000		S				CURTAIN; DOUBLE; 580X490MM; PVC			114,70

??????	534304									
??????	595664900		???????? 8				Prewash from 22", Main view			
.		Alias		S			.			(Euro)
0133	0L0887	503605801					COVERING; INLET LATERAL			100,50
0134	0E5826	RT0003700		S			CURTAIN AXIS; L=580 MM			16,80
0136	0L1767	541616900		S			CURTAIN; PVC; NEWRT			89,22
0137	0L2443	W00017300		S			ROLLER; Ø=40MM; H=16MM; WHITE	Up to Ser. Nr.: 146		5,81
0137	0L2520	547604800		S			ROLLER	From Ser. Nr.: 147		6,02
0138	0L1765	541617200		S			CURTAIN; PVC; NEWRT			101,50
0139	0L1719	5026B8D00			D		RIGHT SIDE; LOWER; NEWRT	From Ser: 1451		130,90
0140	0L0857	515659300		S			ROLL			6,12
0141	0L1170	546631100		S			BUSHING; FOR SPRING NEWRT			7,18
0142	0E5167	W00093300					SPRING BLADE; 38X0,5 MM			56,10
0143	0L1769	5146A2800					AXIS; 22" NEWRT			27,81
0144	0L0888	503606400					TUNNEL; INLET			170,50
0145	0L0975	830636701					PANEL; ASSY			251,70
0146	0L0920	543631100					GASKET			47,60
0147	0L0993	541612500					PLUG; PLASTIC			1,02
0148	0L0861	541612801		S			DOOR CATCH			2,43
0149	0L1173	502698400					BASKET GUIDE; LAT.M600 PREWASH NEWRT			24,56
0150	0L1200	502698301					BASKET SUPPORT; LOWER			13,09
0151	0L2174	549646100		S			WASHER	From Ser. Nr.: 147		1,58
0151	0L2174	549646100		S			WASHER	Up to Ser. Nr.: 146		1,58
0152	0L2522	219614400		S			SNAP RING	From Ser. Nr.: 147		1,02
0153	0L2521	5066A0R00		S			DISC	From Ser. Nr.: 147		4,44
0163	0L1471	543631300		S			GASKET; NEWRT			13,62
0164	0L1470	502697402					BRACKET; FOR GASKET NEWRT			12,25
0165	0L1469	503609200					PLAQUE; FOR GASKET NEWRT			3,69
0166	0L1597	565615200		S	A		DOOR GASKET; NEWRT			1,68
0168	0L1528	507690700		S			SPRING LATCH			11,41
0169	0L1500	830646401	0L2591				BASKET GUIDE; 22"; COMPACT NEWRT	Up to Ser. Nr.: 146		
0169	0L2523	830657U00	0L2591				BASKET GUIDE	From Ser. Nr.: 147		
0169	0L2523	830657U00	0L2591				BASKET GUIDE	From Ser. Nr.: 5151 - Only for RTC180- WTCS180		
0169	0L2523	830657U00	0L2591				BASKET GUIDE	Up to Ser. Nr.: 4501		
0169	0L2591	835621V00					BASKET GUIDE; ASSY; 22" NEWRT	Up to Ser. Nr.: 4501		216,20
0169	0L2591	835621V01					BASKET GUIDE; ASSY; 22" NEWRT	From Ser. Nr.: 4511		216,20
0169	0L3351	83065AQ01					BASKET GUIDE; ASSY; LWC22	From Ser. Nr.: 4511		189,80
0169	0L3351	83065AQ01					BASKET GUIDE; ASSY; LWC22	Up to Ser. Nr.: 5141 - Only for RTC180- WTCS180		189,80
0170	0L1046	507689001					SUPPORT;BACKPANEL SUPPORT	From Ser. Nr.: 909 - Up to Ser. Nr.: 928		16,26

??????	534304									
??????	595664900	???????? 8	Prewash from 22", Main view							
.		Alias		S			.			(Euro)
0170	0L2088	805664Q00						SUPPORT; FOR BACK PANEL; NEWRT	From Ser. Nr.: 929	18,98
0174	0L2329	206008195						WASHER; DIA.15X28	From Ser. Nr.: 020	1,02
0175	0L2324	5146A2401						SPACER	From Ser. Nr.: 020	20,00
0176	0L2328	217018205						SCREW; M14X20	From Ser. Nr.: 020	3,24
0177	0L2167	543633J00						GASKET	From Ser. Nr.: 020	30,45
0178	0L2311	543633H00						GASKET	From Ser. Nr.: 020	30,45
113a	0L1047	830643101						SUPPORT; ASSY; DX NEWRT		34,92
113b	0L1049	830643001						SUPPORT; ASSY; SX NEWRT		34,92



PLATON SERVICE

8 (800) 500-34-41

www.platonservice.com

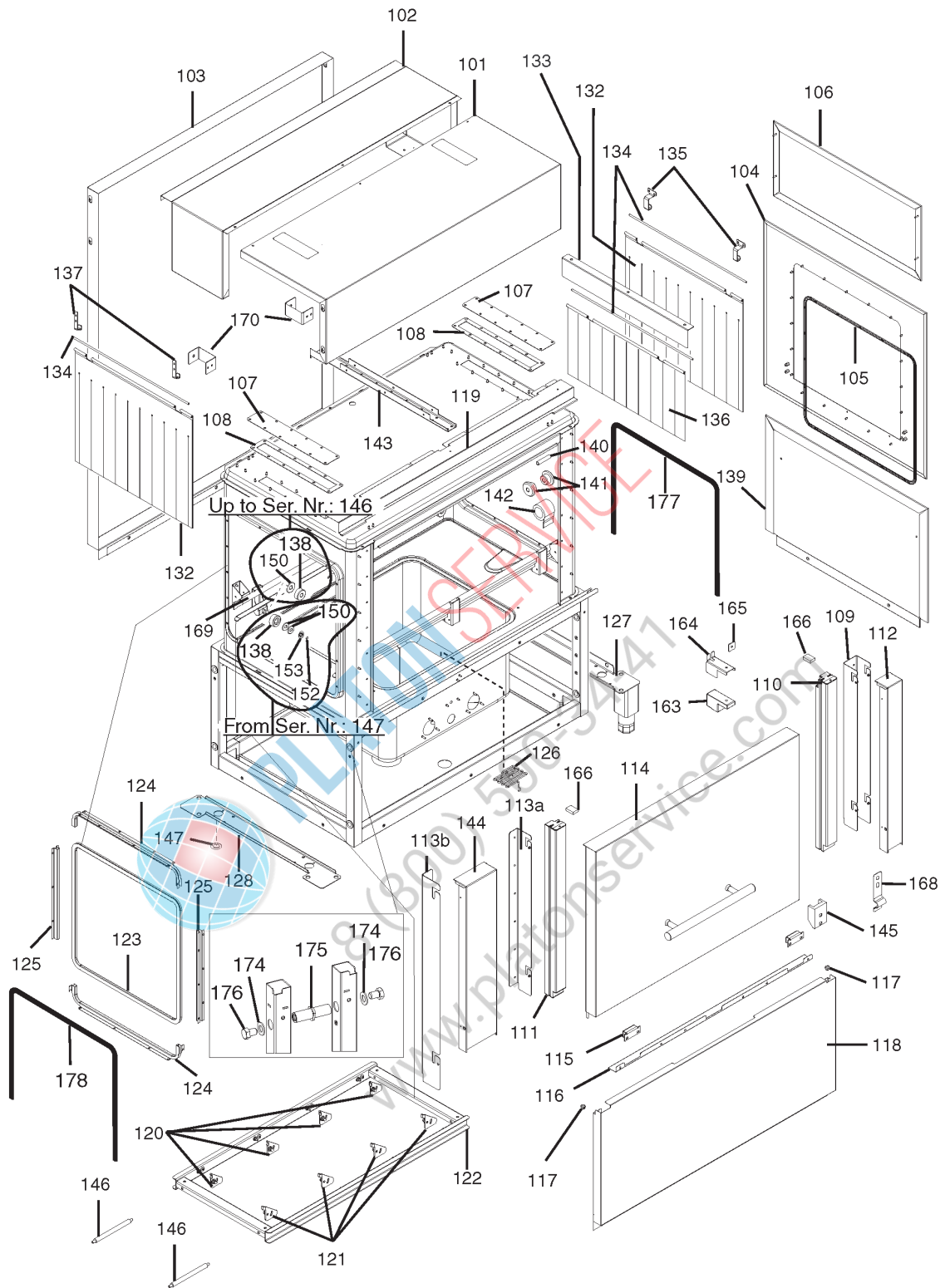

iii. 657001p3
 Prelavaggio da 44", vista generale / Prewash from 44", Main view

Da Ser.Nr./From Ser.nr.: 811

Page: 11 Ed. 2011-12

Doc. Nr.: 595664900

(6-57001)

??????	534304									
??????	595664900		???????? 11					Prewash from 44", Main view		
.		Alias		S						(Euro)
0101	000000	83065GC00							From Ser.: 5151	
0101	0L1723	830654B00						COVER PLATE; ASSY; 44" NEWRT	Up to Ser. Nr.: 908	251,70
0101	0L2041	830654B02						COVERING; ASSY; NEWRT	From Ser. Nr.: 909	263,90
0101	0L2041	830654B02						COVERING; ASSY; NEWRT	Up to Ser.: 5141	263,90
0102	0L1517	830652000						COVERING; COMPACT NEWRT	Up to Ser. Nr.: 908	296,40
0103	0L1721	830654A01						BACK PANEL; ASSY; 44" NEWRT	Up to Ser. Nr.: 908	278,10
0103	0L2040	830654A03						BACK PANEL; NEWRT	From Ser. Nr.: 909 - Up to Ser. Nr.: 146	272,00
0103	0L2542	830657Y00						BACK PANEL	From Ser. Nr.: 147	258,80
0104	0L0880	830638303						PANEL; RH		187,80
0105	0L0875	543629700						GASKET		19,43
0106	0L1584	830651401						SIDE PANEL; ASSY		76,94
0107	0L0877	800667301						PLUG; ASSY		35,02
0108	0L0876	543631001						GASKET		12,57
0109	0L1169	830643202						SUPPORT; FOR PANEL NEWRT		52,98
0110	0L0832	830637101		S				DOOR GUIDE; RH		91,65
0111	0L0833	830637201		S				DOOR GUIDE; LH		91,65
0112	0L0856	830641103						PANEL; SLIM		68,31
0114	0L1510	835620901	0L2461					DOOR ASSEMBLY; 44" NEWRT	Up to Ser: 1450	
0114	0L2461	835621F00						DOOR ASSEMBLY; 44' ECOLAB NEWRT	From Ser: 1451	651,00
0115	0E2898	W00143601						SPRING RETAINER		14,89
0116	0L1492	5046A2301						SPLASH GUARD; NEWRT; DOOR 44"		22,43
0117	0L0839	549644800						PEG		2,84
0118	0L0890	503609901						FRONT PANEL; LOWER		220,30
0119	0L1520	503613802						CRANKCASE; COMPACT NEWRT	Up to Ser.: 5141	72,17
0119	0L3562	5046ABB00						PROTECTION; NEWRT	From Ser.: 5151	56,84
0120	0L1314	5046A3800		S				TOOTH; DX		16,03
0121	0L1315	5046A3900		S				TOOTH; SX		16,03
0122	0L1303	830632401						FEEDING LADDER; M1165 NEWRT		263,90
0123	0L0827	543630300		S				GASKET		26,59
0124	0L0992	502697601						COVERING; NEWRT		36,24
0125	0L0991	502697501						COVERING		25,78
0126	0L2515	5146A4100		S				PROTECTIVE GRATING	From Ser. Nr.: 147	19,79
0127	0L0853	503603601						FOOT WITH FRAME		110,60
0128	0L0854	502696002						SUPPORT; FEET SUPPORT NEWRT		35,73
0132	0L1732	541617000		S				CURTAIN; DOUBLE; 580X490MM; PVC		114,70
0133	0L0852	800667800						SUPPORT; SINGLE SHORT CURTAIN		37,86

??????	534304									
??????	595664900		???????? 11				Prewash from 44", Main view			
.		Alias		S			.			(Euro)
0134	0E5826	RT0003700		S				CURTAIN AXIS; L=580 MM		16,80
0135	0L1172	505600001						HOOK; FOR CURTAIN NEWRT		15,10
0136	0L1733	541617100		S				CURTAIN; SINGLE; PVC		67,09
0137	0L1171	503610500						HOOK; NEWRT		15,52
0138	0L2443	W00017300		S				ROLLER; Ø=40MM; H=16MM; WHITE	Up to Ser. Nr.: 146	5,81
0138	0L2520	547604800		S				ROLLER	From Ser. Nr.: 147	6,02
0139	0L1719	5026B8D00			D			RIGHT SIDE; LOWER; NEWRT	From Ser: 1451	130,90
0140	0L0857	515659300		S				ROLL		6,12
0141	0L1170	546631100		S				BUSHING; FOR SPRING NEWRT		7,18
0142	0E5167	W00093300						SPRING BLADE; 38X0,5 MM		56,10
0143	0L0867	503607302						REINFORCEMENT		22,43
0144	0L0984	830641003						PANEL		80,49
0145	0L0861	541612801		S				DOOR CATCH		2,43
0146	0L0841	514695200						SHAFT		18,68
0147	0L0993	541612500						PLUG; PLASTIC		1,02
0150	0L2174	549646100		S				WASHER	From Ser. Nr.: 147	1,58
0150	0L2174	549646100		S				WASHER	Up to Ser. Nr.: 146	1,58
0152	0L2522	219614400		S				SNAP RING	From Ser. Nr.: 147	1,02
0153	0L2521	5066A0R00		S				DISC	From Ser. Nr.: 147	4,44
0163	0L1471	543631300		S				GASKET; NEWRT		13,62
0164	0L1470	502697402						BRACKET; FOR GASKET NEWRT		12,25
0165	0L1469	503609200						PLAQUE; FOR GASKET NEWRT		3,69
0166	0L1597	565615200		S	A			DOOR GASKET; NEWRT		1,68
0168	0L1528	507690700		S				SPRING LATCH		11,41
0169	0L1505	830646701	0L2590					BASKET GUIDE; 44"; COMPACT NEWRT	Up to Ser. Nr.: 146	
0169	0L2590	835621U00						BASKET GUIDE; ASSY	From Ser. Nr.: 147	235,50
0170	0L1046	507689001						SUPPORT; BACKPANEL SUPPORT	From Ser. Nr.: 909 - Up to Ser. Nr.: 928	16,26
0170	0L2088	805664Q00						SUPPORT; FOR BACK PANEL; NEWRT	From Ser. Nr.: 929	18,98
0174	0L2329	206008195						WASHER; DIA.15X28	From Ser. Nr.: 020	1,02
0175	0L2324	5146A2401						SPACER	From Ser. Nr.: 020	20,00
0176	0L2328	217018205						SCREW; M14X20	From Ser. Nr.: 020	3,24
0177	0L2167	543633J00						GASKET	From Ser. Nr.: 020	30,45
0178	0L2311	543633H00						GASKET	From Ser. Nr.: 020	30,45
113a	0L1047	830643101						SUPPORT; ASSY; DX NEWRT		34,92
113b	0L1049	830643001						SUPPORT; ASSY; SX NEWRT		34,92

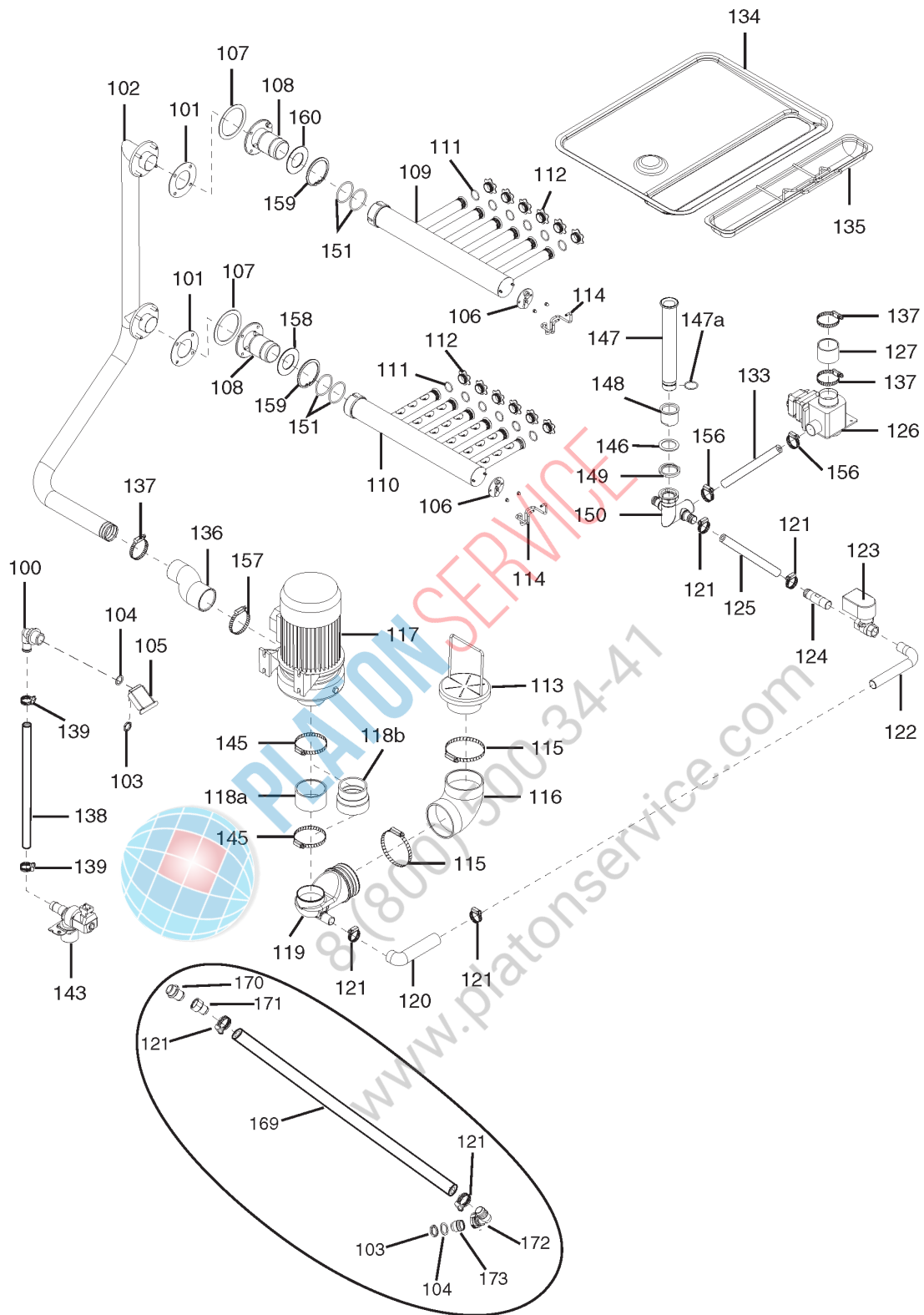

ill. 657001p4
 Lavaggio+Risciacquo da 44", Circuito Idrraulico lavaggio/Wash+Rinse from 44", Wash hydraulic circuit

Da Ser.Nr./From Ser.nr.: 811

Page: 14 Ed.2010-10

Doc. Nr.: 595664900

(6-57001)

??????	534304									
??????	595664900	???????? 14	Wash+Rinse from 44", Wash hydraulic circuit							
.		Alias		S			.			(Euro)
0100	0L0653	511619900		S				PIPE FITTING; 90 GR G 1/2"		23,24
0101	0L0919	543629400		S				GASKET		4,65
0102	0L1187	830632603						TUBE; WASH M1165 NEWRT		189,80
0103	0E5424	W00525400						NUT		4,73
0104	0E5122	W00500800	0L2402					GASKET	Up to Ser.Nr.: 045	
0104	0L2402	569608800		S				GASKET; 29X21MM	From Ser.Nr.: 046	3,28
0105	0E5848	RT0011900						SPLASH GUARD		18,37
0106	0L1370	800669401	0L2773					ARM COUPLING COVER		
0107	0L0923	543632400		S				O-RING		1,02
0108	0L1188	830633101						SUPPORT; FOR WASH TUBE		139,10
0109	0L1709	830654600	0L3473					WASH ARM	Right machine	350,20
0109	0L1710	830654700	0L3474					WASH ARM	Left machine	350,20
0110	0L1709	830654600	0L3473					WASH ARM	Right machine	350,20
0110	0L1710	830654700	0L3474					WASH ARM	Left machine	350,20
0111	0L0922	543632300		S				O-RING; ØI=26,65X2,62 MM		1,02
0112	0L1711	541617400		S				PLUG; FOR WASH ARM		1,68
0113	0L0951	800666601						PUMP STRAINER		104,50
0114	0L0905	514697101	0L2087					HOOK	Up to Ser. Nr.: 928	
0114	0L2087	5146A2100		S				HOOK	From Ser. Nr.: 929	11,09
0115	0L0915	518682700						CLAMP; 100-120		5,29
0116	0L0930	544635700						SLEEVE		57,35
0117	0L1234	611631100		S	A			PUMP; 230-400V 50HZ 3/1,75A 1KW	90/180 b/h	271,00
0117	0L1735	611636900		S				PUMP; 2254/S SX 230/400V 50HZ	140/250 b/h	433,40
0119	0L0928	544635200						SUCTION HOSE; SX		13,16
0120	049880	544631300		S				SLEEVE		13,30
0121	047578	518604001						CLAMP; 26-38		1,80
0122	0L0910	515660200						ELBOW HOSE		29,03
0123	0L1199	696617800		S	A			SOLENOID VALVE; TYPE 224D-024-V120		154,30
0124	0L0912	515660400						TUBE		40,40
0125	049287	140066043		S	A			HOSE; ØE=30MM; ØI=25MM; L=430MM		10,39
0126	0L2506	696618600		S	A			DRAIN VALVE; 24V 50/60HZ		149,20
0127	0L0934	544639900		S				SLEEVE		5,61
0133	0L0939	544683100		S				RUBBER HOSE; L=70MM		11,41
0134	0L0892	504694300						FILTER		271,00
0135	0L0973	830634900						FILTER BASKET; ASSY		169,50
0136	0L0936	544640100						SLEEVE	140/250 b/h	39,08

??????		534304									
??????		595664900		???????? 14		Wash+Rinse from 44", Wash hydraulic circuit					
.		Alias		S			.			(Euro)	
0136	0L1267	544683300		S				SLEEVE; ZF523V NEWRT	90/180 b/h	43,44	
0137	046855	518602801						HOSE CLAMP; 50-70/9		2,00	
0138	048531	140066039						RUBBER HOSE; ØI=12MM;ØE=19,5MM;BY METER	Up to Ser. Nr.: 045	9,55	
0138	049379	140066047	0L3641					HOSE; WRC, 1PC=1130MM	From Ser. Nr.: 046	22,23	
0139	048126	518609801						CLIP; 13-20		1,58	
0143	0L1198	696617400	0L3449					SOLENOID VALVE; 20L/MIN 24V 50-60HZ	Up to Ser.Nr.: 019	17,97	
0143	0L2327	696618400	0L3449	A				WATER SOLENOID VALVE; 20L/ MIN 24V 50-60H	From Ser.Nr.: 020	20,00	
0145	0L0914	518682600						CLAMP		3,91	
0146	065506	246037900						GASKET; ØI=42,86X3,53 MM		1,02	
0147	0L1430	515657801	0L2295					OWERFLOW PIPE; NEWRT	Up to S. Nr. 019		
0147	0L2295	830657300		S				OWERFLOW PIPE	From Ser. Nr.: 020	11,82	
0148	075624	511607200						DRAIN		12,32	
0149	066079	215190400						RING NUT		24,66	
0150	0L0953	805659801		S				DRAIN MANIFOLD		90,03	
0151	0L1276	543633200		S				O-RING; ØI=50X3 MM		1,47	
0156	0L0193	518614400		S				CLMAP; 40-60/9		2,01	
0157	046853	518602901						HOSE CLAMP; 60-80/9		2,53	
0158	0L1216	503614500						SHUTTER; M1165 COMPACT NEWRT	90/180 b/h	6,33	
0158	0L1754	5026B0E00						SHUTTER	140/250 b/h	7,49	
0159	0L1189	219065212		S				SNAP RING		4,28	
0160	0L1185	5026A3000		S				SHUTTER; M1165 MODULARE NEWRT	140/250 b/h	6,76	
0169	0L2426	140600300						HOSE; BY METER; ØINT20X3 (ØEST=26)	Only for 180 From Ser. Nr.: 046	13,30	
0169	0L2426	140600300						HOSE; BY METER; ØINT20X3 (ØEST=26)	Only for 250 From Ser. Nr.: 046	13,30	
0169	0L2426	140600300						HOSE; BY METER; ØINT20X3 (ØEST=26)	Only for 90 and 140 From Ser. Nr.: 046	13,30	
0170	0L2423	5146A3B00						RUBBER HOLDER; MALE; G 1/2"	From Ser. Nr.: 046	24,66	
0171	0L2424	5146A3C00						RUBBER HOLDER; FEMALE; G 1/2"	From Ser. Nr.: 046	24,66	
0172	0L0918	541613400		S				CLUTCH	From Ser. Nr.: 046	8,77	
0173	0L2425	5146A0100		S				THREAD QUICK CONNECTION	From Ser. Nr.: 046	20,40	
118a	0L1734	544685900						SUCTION HOSE	140/250 b/h	28,32	
118b	0L1354	544639800						SLEEVE; FOR PUMP	90/180 b/h	23,85	

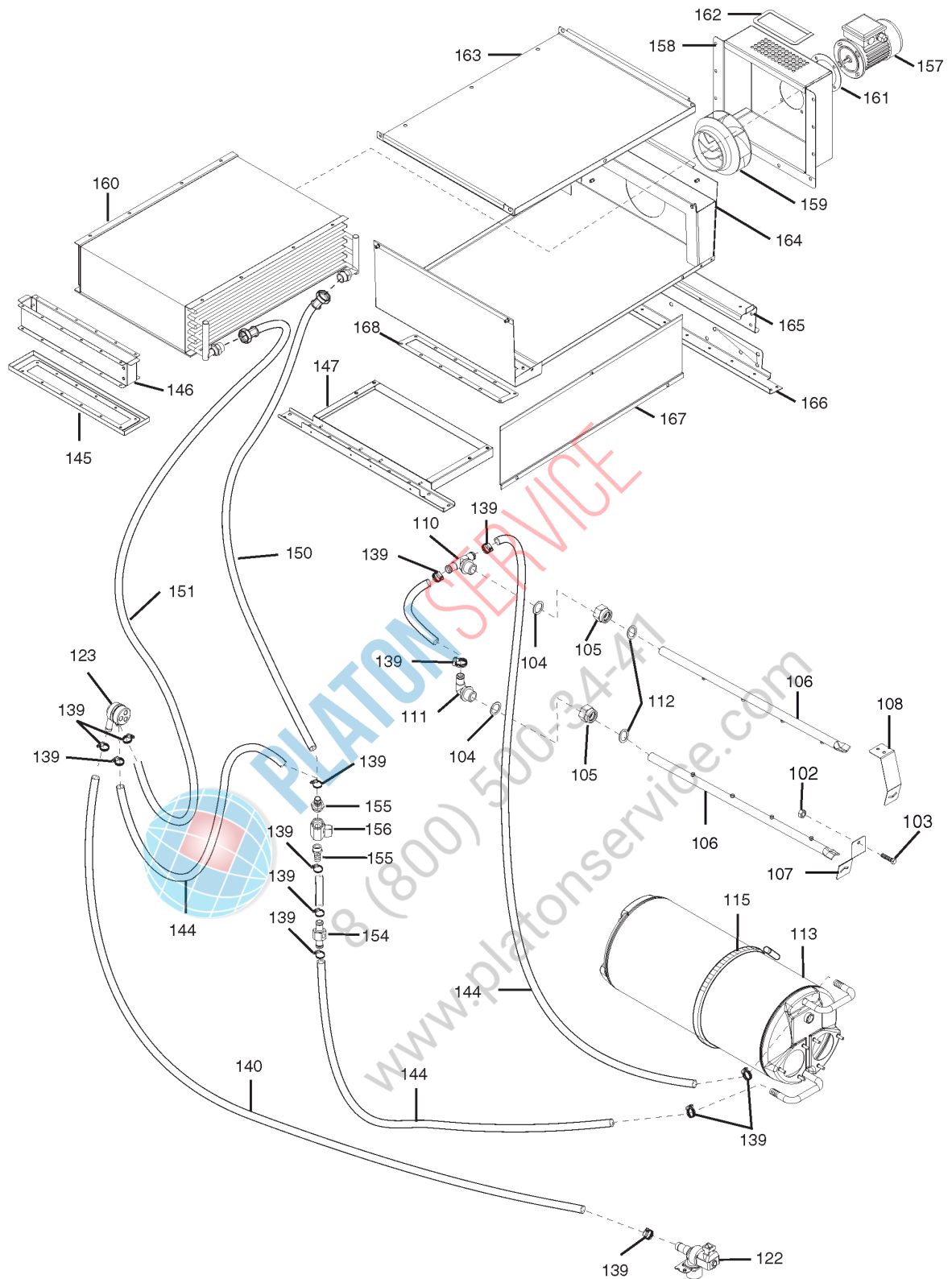

ill. 657001p5

Lavaggio+Risciacquo da 44" , Circuito Idrraulico a pressione risciacquo/ Wash+Rinse from 44" , Rinse pressure hydraulic circuit

Da Ser.Nr./From Ser.nr.: 811

Page: 17 Ed. 2016-07

Doc. Nr.: 595664900

(6-57001)

??????	534304									
??????	595664900	???????? 17	Wash+Rinse from 44" , Rinse pressure hydraulic circuit							
.		Alias		S			.			(Euro)
0102	0TH077	218574005	034496					NUT; HEX M6	From Ser. Nr.: 147	
0103	0L2413	217014145					Kit	SCREW; SET 100PCS; M6X14	From Ser. Nr.: 147	20,30
0104	0E5122	W00500800	0L2402					GASKET	Up to Ser.Nr.: 045	
0104	0L2402	569608800		S				GASKET; 29X21MM	From Ser.Nr.: 046	3,28
0105	0L0907	514698201		S				NUT		86,38
0106	0L1467	830650900						RINSE ARM; ASSY	Up to Ser. Nr.: 146 - For RTC250/WTC250	85,87
0106	0L1468	830651100						WASH ARM; ASSY; NEWRT	Up to Ser. Nr.: 146 - Not for RTC250/WTC250	50,75
0106	0L2529	830657M00						WASH ARM	From Ser. Nr.: 147 - Not for RTC250/WTC250	54,20
0106	0L2631	830657N00						RINSE ARM	From Ser. Nr.: 147 - For RTC250/WTC250	54,20
0107	0L1463	5056A0800						SPRING; LOWER; NEWRT	Up to Ser. Nr.: 146	21,01
0107	0L2518	5056A1J00						LOWER SPRING	From Ser. Nr.: 147	19,18
0108	0L1462	5056A0700						SPRING; UPPER; NEWRT	Up to Ser. Nr.: 146	21,72
0108	0L2517	5056A1H00						UPPER SPRING	From Ser. Nr.: 147	19,18
0110	0L0652	511619800		S				PIPE FITTING; T G 1/2"		27,81
0111	0L0653	511619900		S				PIPE FITTING; 90 GR G 1/2"		23,24
0112	0E5118	W00524500						O-RING; DI=17,3MM; DE=22,1MM		1,02
0113	0L1766	850662G00		S				BOILER; ASSY; NEWRT	Up to Ser.Nr.: 851	245,60
0113	0L1766	850662G01		S				BOILER; ASSY; NEWRT	From Ser.Nr.: 022 - Not for Middle East	245,60
0113	0L1959	850663500	0L1766					BOILER; ASSY; COMPACT EUROPA NEWRT	From Ser.Nr.: 852 - Up to Ser.Nr.: 021 - Not for Middle East	
0113	0L1983	850663L01						BOILER; ASSY; COMPACT EUROPA AISI 316L	For Middle East	624,00
0115	0L2551	518684F00						CLAMP; 200-220 H12MM	Inox/ Stainless Steel	14,46
0122	0L1198	696617400	0L3449					SOLENOID VALVE; 20L/MIN 24V 50-60HZ	Up to Ser.Nr.: 019	17,97
0122	0L2327	696618400	0L3449		A			WATER SOLENOID VALVE; 20L/MIN 24V 50-60H	From Ser.Nr.: 020	20,00
0123	049332	544625400	0L1892					VALVOLA NON RITORNO; DVGW	Up to Ser.Nr.: 835	
0123	0L1892	544685800		S				NONRETURN VALVE; HIGH TEMPERATURE	From Ser.Nr.: 836	18,09
0139	048126	518609801						CLIP; 13-20		1,58
0140	048531	140066039						RUBBER HOSE; ØI=12MM;ØE=19,5MM;BY METER	Up to Ser. Nr.: 045	9,55
0140	049379	140066047	0L3641					HOSE; WRC, 1PC=1130MM	From Ser. Nr.: 046	22,23
0144	048531	140066039						RUBBER HOSE; ØI=12MM;ØE=19,5MM;BY METER		9,55
0145	0L1727	5046A6B00						BOWL; CU 44"; NEWRT	Up to Ser.: 5141	118,80
0146	0L1729	830654H00						CONVEYOR; ASSY; CU 44" NEWRT	Up to Ser.: 5141	69,22
0147	0L1728	800672400						BOWL; ASSY	Up to Ser.: 5141	143,10
0150	0L0988	830642900						DRAIN HOSE; L=2450MM		32,99
0151	0L0987	830642800						FEEDER HOSE; L=1450MM		26,69

??????		534304									
??????		595664900		???????? 17		Wash+Rinse from 44" , Rinse pressure hydraulic circuit					
.		Alias		S			.				(Euro)
0154	0E3080	W00502600							HOSE NIPPLE		18,27
0155	0L0040	514692200		S					RUBBER HOLDER		16,47
0156	0L1351	514600200							TAP; FEED REGULATOR		22,43
0157	0L0946	611630400		S	A				FAN MOTOR		190,80
0158	0L0952	800668202							MOTOR BRACKET; CU NEWRT	Up to Ser.: 5141	359,30
0158	0L3569	541618H00	0L3765						IMPELLER COVER FOR MOTOR; NEW CU	From Ser.: 5151	99,47
0158	0L3569	541618H00	0L3765						IMPELLER COVER FOR MOTOR; NEW CU	Up to Ser.: 6261	99,47
0158	0L3765	83065P200		S	D				MOTOR SUPPORT	From Ser.: 6271	
0159	0L0941	549644900							FAN BLADE		179,70
0160	0L1730	511620800	0L3573						HEAT EXCHANGER; NEWRT	Up to Ser.: 5141	
0160	0L3573	511621200		S					HEAT EXCHANGER; FOR ESD	From Ser.: 5151	680,00
0161	0L3570	543635S00							MOTOR GASKET; NEW CU	From Ser.: 5151	5,18
0162	0L0689	140036014	046583	S	A				ELASTOMER GASKET; BY METER	From Ser.: 5151	2,03
0163	0L3560	5046AB901							LID; CU NEWRT	From Ser.: 5151	93,38
0164	0L3566	86065D600							BATTERY ASSEMBLY SUPPORT; ASSY	From Ser.: 5151	249,70
0165	0L3567	83065D800							BASE ASSEMBLY SUPPORT CU; ASSY	From Ser.: 5151	48,72
0166	0L3568	83065D901							CROSSPIECE; ASSY	From Ser.: 5151	46,69
0167	0L3561	83065DD01							COVERING; ASSY; CU NEWRT	From Ser.: 5151	56,84
0168	0L0876	543631001							GASKET	From Ser.: 5151	12,57

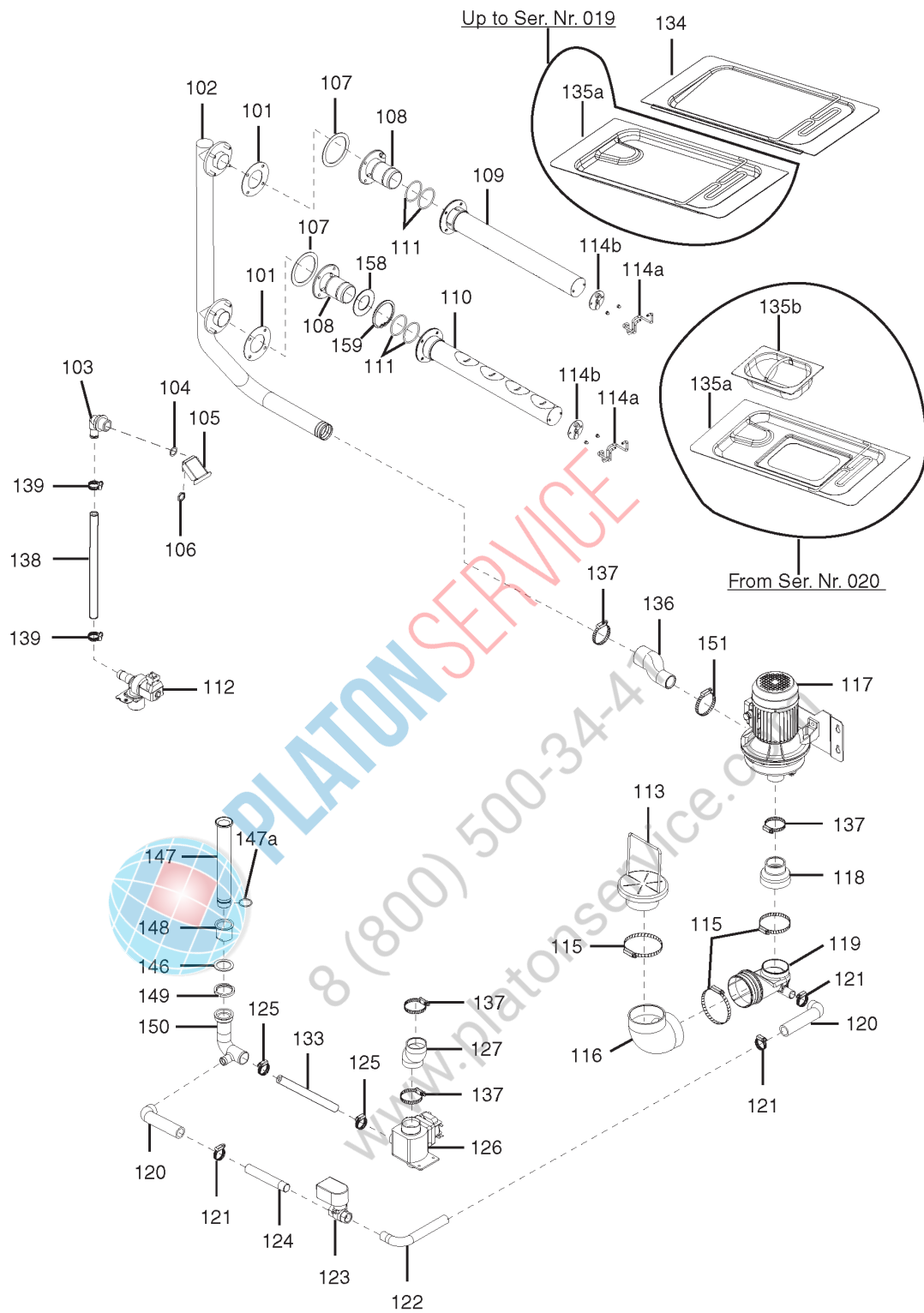

iii. 657001p6

Prelavaggio da 22", Circuito Idraulico/ Prewash from 22", Hydraulic circuit

Da Ser.Nr./From Ser.nr.: 811

Page: 20 Ed.2010-10

Doc. Nr.: 595664900

(6-57001)

??????	534304								
??????	595664900		???????? 20				Prewash from 22", Hydraulic circuit		
.		Alias		S			.		(Euro)
0101	0L0919	543629400		S			GASKET		4,65
0102	0L1186	830632703					TUBE; WASH M600 NEWRT		187,80
0103	0L0653	511619900		S			PIPE FITTING; 90 GR G 1/2"		23,24
0104	0E5122	W00500800	0L2402				GASKET	Up to Ser.Nr.: 045	
0104	0L2402	569608800		S			GASKET; 29X21MM	From Ser.Nr.: 046	3,28
0105	0E5848	RT0011900					SPLASH GUARD		18,37
0106	0E5424	W00525400					NUT		4,73
0107	0L0923	543632400		S			O-RING		1,02
0108	0L1188	830633101					SUPPORT; FOR WASH TUBE		139,10
0109	0L0974	830635702					WASH ARM	Up to Ser:5051	210,10
0109	0L3471	83065FS00					WASHING JET; UPPER; NEWRT	From Ser:5061	212,10
0110	0L0985	830641302					WASH ARM	Up to Ser:5051	211,10
0110	0L3472	83065FV00					WASHING JET; LOWER; NEWRT	From Ser:5061	212,10
0111	0L1276	543633200		S			O-RING; ØI=50X3 MM		1,47
0112	0L1198	696617400	0L3449				SOLENOID VALVE; 20L/MIN 24V 50-60HZ	Up to Ser.Nr.: 019	17,97
0112	0L2327	696618400	0L3449		A		WATER SOLENOID VALVE; 20L/ MIN 24V 50-60H	From Ser.Nr.: 020	20,00
0113	0L0951	800666601					PUMP STRAINER		104,50
0114	000000								
0115	0L0915	518682700					CLAMP; 100-120		5,29
0116	0L0930	544635700					SLEEVE		57,35
0117	0L1195	611631200					PUMP; 220-380V 50HZ 1.4/0.8A		314,70
0118	0L1355	544683600					SLEEVE; PUMP NEWRT		23,65
0119	0L1551	544635100					SUCTION HOSE; DX NEWRT		13,37
0120	049880	544631300		S			SLEEVE		13,30
0121	047578	518604001					CLAMP; 26-38		1,80
0122	0L0910	515660200					ELBOW HOSE		29,03
0123	0L1199	696617800		S	A		SOLENOID VALVE; TYPE 224D-024-V120		154,30
0124	0L0911	515660300					TUBE		19,00
0125	0L0193	518614400		S			CLMAP; 40-60/9		2,01
0126	0L2506	696618600		S	A		DRAIN VALVE; 24V 50/60HZ		149,20
0127	0L0935	544640000					SLEEVE		20,60
0133	0L0939	544683100		S			RUBBER HOSE; L=70MM		11,41
0134	0L1167	830643401					TANK FILTER; TILTED M600 NEWRT		258,80
0136	0L1268	544683500					SLEEVE; 1212 NEWRT		43,85
0137	046855	518602801					HOSE CLAMP; 50-70/9		2,00
0138	048531	140066039					RUBBER HOSE; ØI=12MM;ØE=19,5MM;BY METER	Up to Ser. Nr.: 045	9,55

??????	534304								
??????	595664900	???????? 20	Prewash from 22", Hydraulic circuit						
.		Alias		S		.			(Euro)
0138	049379	140066047	0L3641				HOSE; WRC, 1PC=1130MM	From Ser. Nr.: 046	22,23
0139	048126	518609801					CLIP; 13-20		1,58
0146	065506	246037900					GASKET; ØI=42,86X3,53 MM		1,02
0147	0L1431	515657902	0L2296				OWERFLOW PIPE; NEWRT	Up to S. Nr. 019	
0147	0L2296	830657400		S			OWERFLOW PIPE	From S. Nr. 020	11,82
0148	075624	511607200					DRAIN		12,32
0149	066079	215190400					RING NUT		24,66
0150	0L0954	805659902					DRAIN MANIFOLD		69,83
0151	046878	518602701					HOSE CLAMP; 35-50/9		1,91
0158	0L1184	5026A3100					SHUTTER; M600 NEWRT		6,76
0159	0L1189	215065212		S			SNAP RING		4,28
135a	0L1166	830643300				CGX201 0-09	TANK FILTER; PREWASH M600 NEWRT	Up to Ser. Nr.: 019	235,50
135a	0L2290	830656100					FILTER	From Ser. Nr.: 020	276,10
135b	048252	830617602					FILTER	From Ser. Nr.: 020	62,83



PLATON SERVICE
 8 (800) 500-34-41
 www.platonservice.com

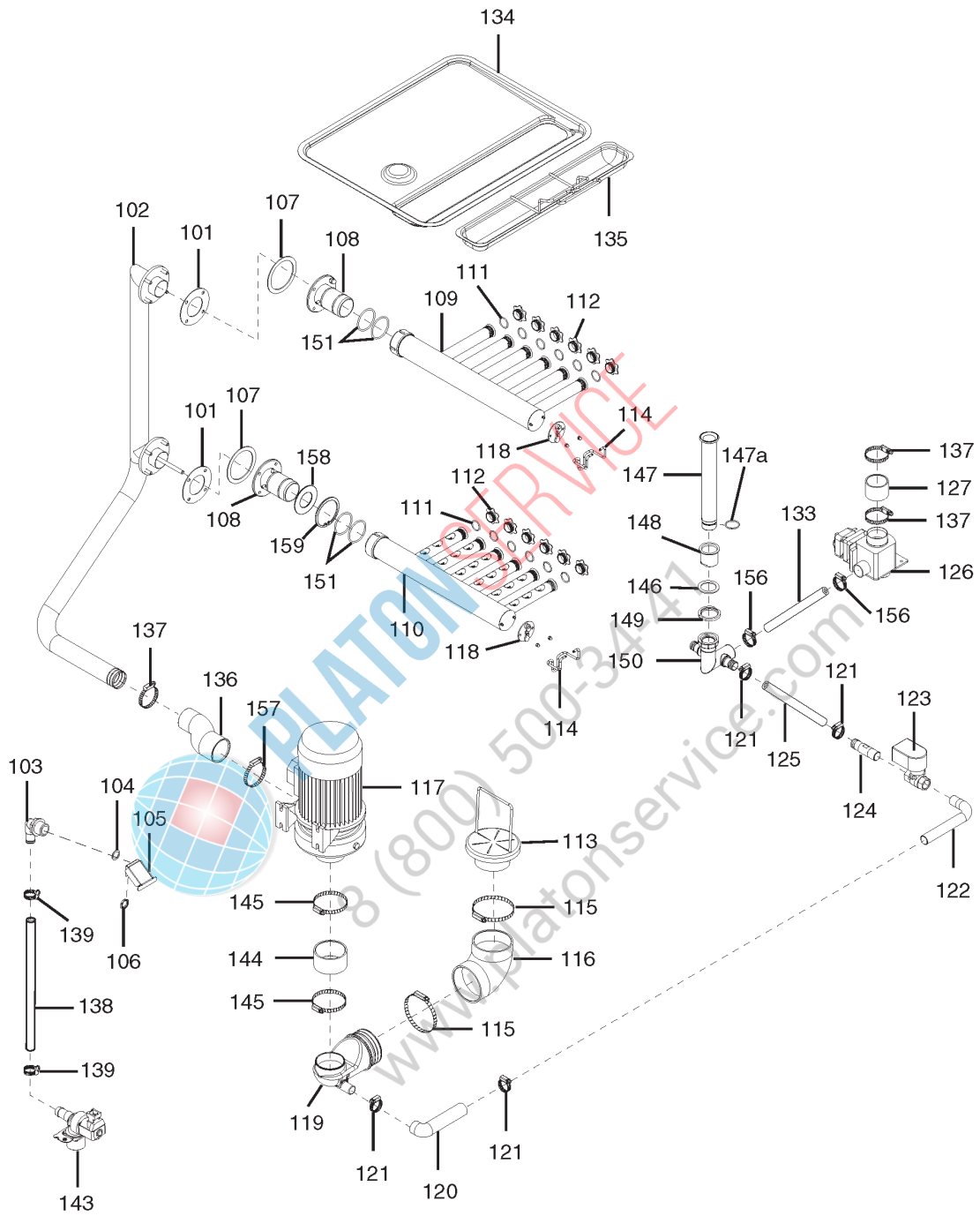

ill. 657001p7

Prelavaggio da 44", Circuito Idraulico/ Prewash from 44", Hydraulic circuit

Da Ser.Nr./From Ser.nr.: 811

Page: 23 Ed.2010-10

Doc. Nr.: 595664900

(6-57001)

??????	534304									
??????	595664900		???????? 23				Prewash from 44", Hydraulic circuit			
.		Alias		S			.			(Euro)
0101	0L0919	543629400		S			GASKET			4,65
0102	0L1107	830632603					PROTECTION; FRONT			18,36
0103	0L0653	511619900		S			PIPE FITTING; 90 GR G 1/2"			23,24
0104	0E5122	W00500800	0L2402				GASKET	Up to Ser.Nr.: 045		
0104	0L2402	569608800		S			GASKET; 29X21MM	From Ser.Nr.: 046		3,28
0105	0E5848	RT0011900					SPLASH GUARD			18,37
0106	0E5424	W00525400					NUT			4,73
0107	0L0923	543632400		S			O-RING			1,02
0108	0L1188	830633101					SUPPORT; FOR WASH TUBE			139,10
0109	0L1709	830654600	0L3473				WASH ARM	Up to Ser:5051 - Left machine		350,20
0109	0L1709	830654600	0L3473				WASH ARM	Up to Ser:5051 - Right machine		350,20
0109	0L3473	83065FW00					WASHING JET; LEFT/RIGHT	From Ser:5061 - Left machine		352,20
0109	0L3473	83065FW00					WASHING JET; LEFT/RIGHT	From Ser:5061 - Right machine		352,20
0110	0L1710	830654700	0L3474				WASH ARM	Up to Ser:5051 - Left machine		350,20
0110	0L1710	830654700	0L3474				WASH ARM	Up to Ser:5051 - Right machine		350,20
0110	0L3474	83065FX00					WASHING JET; RIGHT/LEFT	From Ser:5061 - Left machine		352,20
0110	0L3474	83065FX00					WASHING JET; RIGHT/LEFT	From Ser:5061 - Right machine		352,20
0111	0L0922	543632300		S			O-RING; ØI=26,65X2,62 MM			1,02
0112	0L1711	541617400		S			PLUG; FOR WASH ARM			1,68
0113	0L0951	800666601					PUMP STRAINER			104,50
0114	0L0905	514697101	0L2087				HOOK	Up to Ser. Nr.: 928		
0114	0L2087	5146A2100		S			HOOK	From Ser. Nr.: 929		11,09
0115	0L0915	518682700					CLAMP; 100-120			5,29
0116	0L0930	544635700					SLEEVE			57,35
0117	0L1234	611631100		S	A		PUMP; 230-400V 50HZ 3/1,75A 1KW			271,00
0118	0L1370	800669401	0L2773				ARM COUPLING COVER			
0119	0L0928	544635200					SUCTION HOSE; SX			13,16
0120	049880	544631300		S			SLEEVE			13,30
0121	047578	518604001					CLAMP; 26-38			1,80
0122	0L0910	515660200					ELBOW HOSE			29,03
0123	0L1199	696617800		S	A		SOLENOID VALVE; TYPE 224D-024-V120			154,30
0124	0L0912	515660400					TUBE			40,40
0125	049287	140066043		S	A		HOSE; ØE=30MM; ØI=25MM; L=430MM			10,39
0126	0L2506	696618600		S	A		DRAIN VALVE; 24V 50/60HZ			149,20
0127	0L0934	544639900		S			SLEEVE			5,61
0133	0L0939	544683100		S			RUBBER HOSE; L=70MM			11,41

??????		534304									
??????		595664900		????????? 23		Prewash from 44", Hydraulic circuit					
.		Alias		S			.				(Euro)
0134	0L0892	504694300							FILTER		271,00
0135	0L0973	830634900							FILTER BASKET; ASSY		169,50
0136	0L1267	544683300		S					SLEEVE; ZF523V NEWRT		43,44
0137	046855	518602801							HOSE CLAMP; 50-70/9		2,00
0138	048531	140066039							RUBBER HOSE; ØI=12MM;ØE=19,5MM;BY METER	Up to Ser. Nr.: 045	9,55
0138	049379	140066047	0L3641						HOSE; WRC, 1PC=1130MM	From Ser. Nr.: 046	22,23
0139	048126	518609801							CLIP; 13-20		1,58
0143	0L1198	696617400	0L3449						SOLENOID VALVE; 20L/MIN 24V 50-60HZ	Up to Ser.Nr.: 019	17,97
0143	0L2327	696618400	0L3449	A					WATER SOLENOID VALVE; 20L/ MIN 24V 50-60H	From Ser.Nr.: 020	20,00
0144	0L1354	544639800							SLEEVE; FOR PUMP		23,85
0145	0L0914	518682600							CLAMP		3,91
0146	065506	246037900							GASKET; ØI=42,86X3,53 MM		1,02
0147	0L1430	515657801	0L2295						OWERFLOW PIPE; NEWRT	Up to S. Nr. 019	
0147	0L2295	830657300		S					OWERFLOW PIPE	From Ser. Nr.: 020	11,82
0148	075624	511607200							DRAIN		12,32
0149	066079	215190400							RING NUT		24,66
0150	0L0953	805659801		S					DRAIN MANIFOLD		90,03
0151	0L1276	543633200		S					O-RING; ØI=50X3 MM		1,47
0156	0L0193	518614400		S					CLMAP; 40-60/9		2,01
0157	046853	518602901							HOSE CLAMP; 60-80/9		2,53
0158	0L1216	503614500							SHUTTER; M1165 COMPACT NEWRT		6,33
0159	0L1189	215065212		S					SNAP RING		4,28

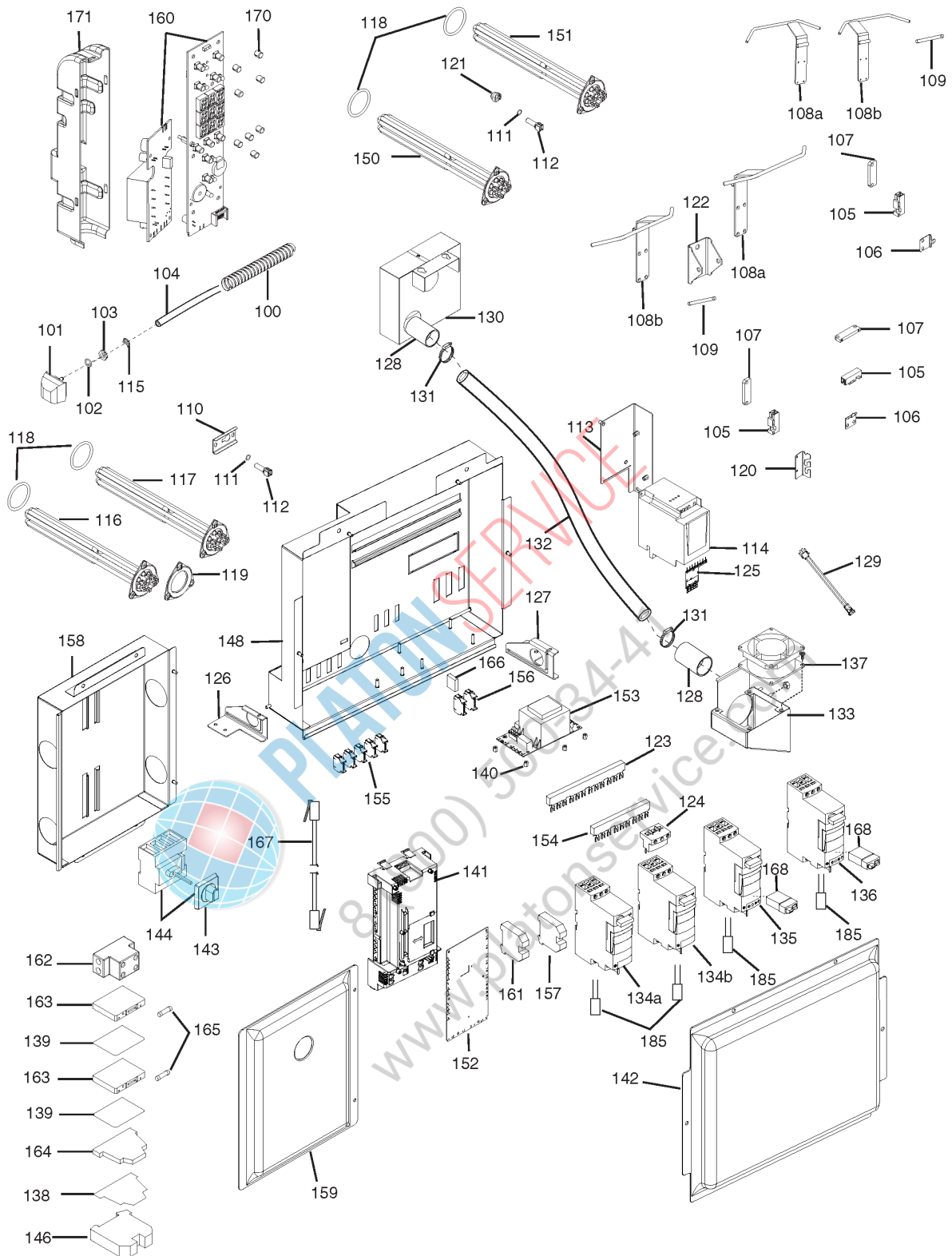

iii. 657001p8

Lavaggio+Risciacquo da 44", Componenti elettrici/ Wash+Rinse from 44", Electrical components

Da Ser.Nr./From Ser.nr.: 811

Page: 26 Ed. 2011-12

Doc. Nr.: 595664900

(6-57001)

??????		534304											
??????		595664900		???????? 26		Wash+Rinse from 44", Electrical components							
.		Alias		S			.					(Euro)	
0100	0L1948	W00050701	0L1949	S						SHEATH			
0101	048308	542604901								AIR TRAP; FOR PRESSURE GAUGE		4,44	
0102	068642	246035800								O-RING; ØI=15,54X2,62		1,02	
0103	049268	544623800								HEX NUT; M14X1,5		1,80	
0104	072393	W00537200								HOSE; Ø=4X7,4MM; L=500CM; PRESSURE SWITC		11,67	
0105	049621	654600000						+		REED SWITCH		15,00	
0106	0L3164	502698502		S						SENSOR SUPPORT		9,93	
0107	0L2534	699605900		S						MAGNET; 63X18X7MM		24,16	
0109	0L1449	514699000								AXIS; NEWRT		5,60	
0110	0L0366	507683800		S						SUPPORT		3,44	
0111	0L2303	543633Z00		S						O-RING; DIA.9,25X1,78		1,02	
0112	049643	124294000								TEMPERATURE PROBE		9,76	
0113	0L1596	5146A1600								SUPPORT	Up to Ser. Nr.: 146	23,75	
0113	0L2508	830657K00								STIRRUP; ASSY	From Ser. Nr.: 147	20,00	
0114	0L1282	624605700	0L1913							INVERTER; ATV11 200/240V 50/60HZ	Up to Ser. Nr.: 835		
0114	0L1913	624606100			D		CGX201 1-04			INVERTER; ATV11 0.55KW 200/240V 50/60	From Ser. Nr.: 836 - Up to Ser. Nr.: 146	319,70	
0114	0L2511	830658900		S	A			+		INVERTER ATV12; 0,55KW 200/240V 50/60HZ	From Ser. Nr.: 147 - Up to Ser. Nr.: 4501	351,20	
0114	0L3457	83065DV00								INVERTER; ATV12	From Ser. Nr.: 4511	356,30	
0115	0L0082	518613000		S						CLAMP; DIA. 7,3-7,8MM		1,02	
0116	0L1005	617623100		S	A					HEATING ELEMENT; 6000W 230V	230 V - not for 90 b/h	79,17	
0117	0L1006	617623000		S	A					HEATING ELEMENT; 6000W 230V	230 V - not for 90 b/h	80,19	
0117	0L1035	617623200	0L2759							HEATING ELEMENT; 10500W 230V	230 V - only for 90 - b/h Up to Ser. Nr.: 040		
0117	0L2242	617632100	0L2759							HEATING ELEMENT; 230V-10500W; RIGHT	230 V - only for 90 - b/h From Ser. Nr.: 041		
0118	000000	W00525000											
0119	049928	507682600								FLANGE	Up to Ser. Nr.: 146	13,52	
0119	0L2629	511620B00								FLANGE	From Ser. Nr.: 147	12,46	
0120	0L1866	5066A0500	0L1871	S						SUPPORT; FOR REED SENSOR			
0121	0L0280	514693100		S	A					STUFFING BOX		11,51	
0122	0L1731	5066A0400								BRACKET		14,79	
0123	0L1004	639626900								CONNECTION BAR	for 4 starter controller	34,41	
0124	0L1013	639626600								TERMINAL BOARD; GV1-G09 63A	Up to Ser.Nr.: 908	24,46	
0125	0L2510	673611S00		S	A					PCB	Up to Ser. Nr.: 4501	80,69	
0126	0L1329	5026A0200								GUIDE; DX M600 NEWRT	Not for 140 b/h	21,11	
0126	0L1619	5026A5300								GUIDE; RIGHT; NEWRT	Only for 140 b/h	28,52	
0127	0L1595	5026A5400								GUIDE; SX; ELECTRICAL BOX		24,26	
0128	0L2552	544687900								SLEEVE	From Ser. Nr.: 147	15,31	

??????		534304									
??????		595664900		???????? 26		Wash+Rinse from 44", Electrical components					
.		Alias		S			.				(Euro)
0129	0L2564	638689S00			D			WIRING HARNESS	From Ser. Nr.: 147		12,63
0130	0L2558	800674400						AIR GUIDE	From Ser. Nr.: 147		27,20
0131	0L0193	518614400		S				CLMAP; 40-60/9	From Ser. Nr.: 147		2,01
0132	000000	140600601							From Ser. Nr.: 4511		
0132	0L2505	140600400						HOSE; BY METER	From Ser. Nr.: 147		42,43
0133	0L2559	830658700						AIR GUIDE	From Ser. Nr.: 147		41,92
0135	0L1222	648614102		S				SWITCH; MOTOR START-UP UNIT	1.25A÷5A		158,30
0136	0L1297	648613901		S				AUTOMATIC CIRCUIT BREAKER	0.35A÷1.4A - Not for 90 b/h		158,30
0137	0L2175	549646500		S				FAN; 80X80X38 208/240V 50/60HZ	From Ser. Nr.: 147		121,80
0138	0L1593	639628800						END SECTION			2,96
0139	0L1594	639628600						END SECTION			3,48
0140	088653	516807900		S				SPACER			2,23
0141	0L1738	673611100		S	A			PCB; MEC12R RT SLAVE; WITH BOX	Up to Ser: 4501		311,60
0141	0L3461	673612F02						PCB; WITH BOX; MEC 12 RT	From Ser: 4511		312,60
0142	0L1202	541614700						COVERING; NEWRT			44,96
0143	0L0698	640612700			D	CGX200 9-02		KNOB			29,94
0144	0L0363	640612500			D	CGX200 9-02		MAIN SWITCH; 4-P 125A	Up to S.N.019		138,00
0144	0L2066	640613300		S	A			MAIN SWITCH; WITH KNOB	From S.N.020		140,10
0146	0E5851	W00509000						CONNECTION; EARTH			21,52
0148	0L1708	850662A01						EL. COMPONENTS BOX; NEWRT			152,30
0150	0L1005	617623100		S	A			HEATING ELEMENT; 6000W 230V			79,17
0150	0L1035	617623200	0L2759					HEATING ELEMENT; 10500W 230V			
0150	0L2242	617632100	0L2759					HEATING ELEMENT; 230V-10500W; RIGHT	Only for 250 b/h Up to Ser. Nr.: 040		
0151	0L1006	617623000		S	A			HEATING ELEMENT; 6000W 230V	Only for 250 b/h From Ser. Nr.: 041		80,19
0152	0L1737	673601120		S	A			PCB			133,00
0153	0L1408	624605901	0L2526					TRANSFORMER; 230V/24V 50VA NEWRT	Up to S.N.019		
0153	0L2191	624606301	0L2526					TRANSFORMER; CPL; WITH CARD	From S.N.020 - Up to Ser. Nr.: 146		
0153	0L2526	624606500		S	A			PCB BOARD TRANSFORMER; 230V/24V-50VA	From Ser. Nr.: 147		123,80
0154	0L1226	639626800						CONNECTION BAR			28,01
0155	0L1227	639627800						CONNECTOR; 8VIE R2.5	for 3 starter controller		12,57
0156	0L1228	639627900						CONNECTOR; 10VIE R2.5			11,61
0157	0L1245	639628400						TERMINAL; BLU 4 MMQ			4,54
0158	0L1248	850659801						EL. COMPONENTS BOX	Up to Ser. Nr.: 146		115,70
0158	0L2632	850664C00						EL. COMPONENTS BOX	From Ser. Nr.: 147		115,70
0159	0L1249	541614800						PROTECTION BOX			29,94
0160	0L1736	805664603	0L2630					USER INTERFACE BOARD; ASSY	Up to Ser. Nr.: 143		

??????	534304									
??????	595664900	???????? 26						Wash+Rinse from 44", Electrical components		
.		Alias		S			.			(Euro)
0160	0L2630	805664604		S	A			USER INTERFACE BOARD	From Ser. Nr.: 144	317,70
0160	0L2630	805664604		S	A			USER INTERFACE BOARD	Up to Ser. Nr.: 144	317,70
0160	0L3460	805666L01						USER INTERFACE BOARD; RT COMPACT UI LV	From Ser. Nr.: 4511	318,70
0161	0L1298	639628900						TERMINAL; BROWM WDU 4 MM	161	5,95
0162	0L1293	639627200						TERMINAL BOARD	162	21,92
0163	0L1294	652608100						FUSE CARRIER	163	18,88
0164	0L1296	639628700						TERMINAL	164	26,69
0165	0L1295	652608200		S				FUSE; 5X20 T10A	165	1,02
0166	0L2556	699605B00						MALE CONNECTOR	Qty 2 for 90 & 140 b/h - Qty 1 for 180 & 250 b/h - From Ser. Nr.: 147	4,85
0167	0L1396	639629000	0L2212					CABLE; RJ11 3600MM	Not for 250 b/h Up to S.N.019	
0167	0L1432	639629200		S				TELEPHONE CABLE; L=6000 MM	Only for 250 b/h Up to S.N.019	22,74
0167	0L2212	639629J00		S				TELEPHONE CABLE; L=5000MM	From S.N.020	33,50
0167	0L3458	639629200						COMMUNICATION CABLE; L=6000MM	Only for 250 b/h From S.N.4511	27,61
0168	0L1441	648615200		S	A			CONTACT; LUFC00 S204	168	42,93
0170	002670	548836902						EXTENSION; L=6,95MM	170	1,02
0171	0L1483	541616401						PROTECTION BOX; LV NEWRT	171	35,73
0185	0L1771	694606300						RIF FILTER; 0.22MF 47OHM 250V		21,32
108a	0L1165	830645901						LEVER; START SX		52,68
108b	0L1164	830645801						LEVER; START DX		52,68
134a	0L1016	648614301		S	A			SWITCH; MOTOR START-UP UNIT	8A÷32A	138,00
134b	0L1016	648614301		S	A			SWITCH; MOTOR START-UP UNIT	8A÷32A	138,00

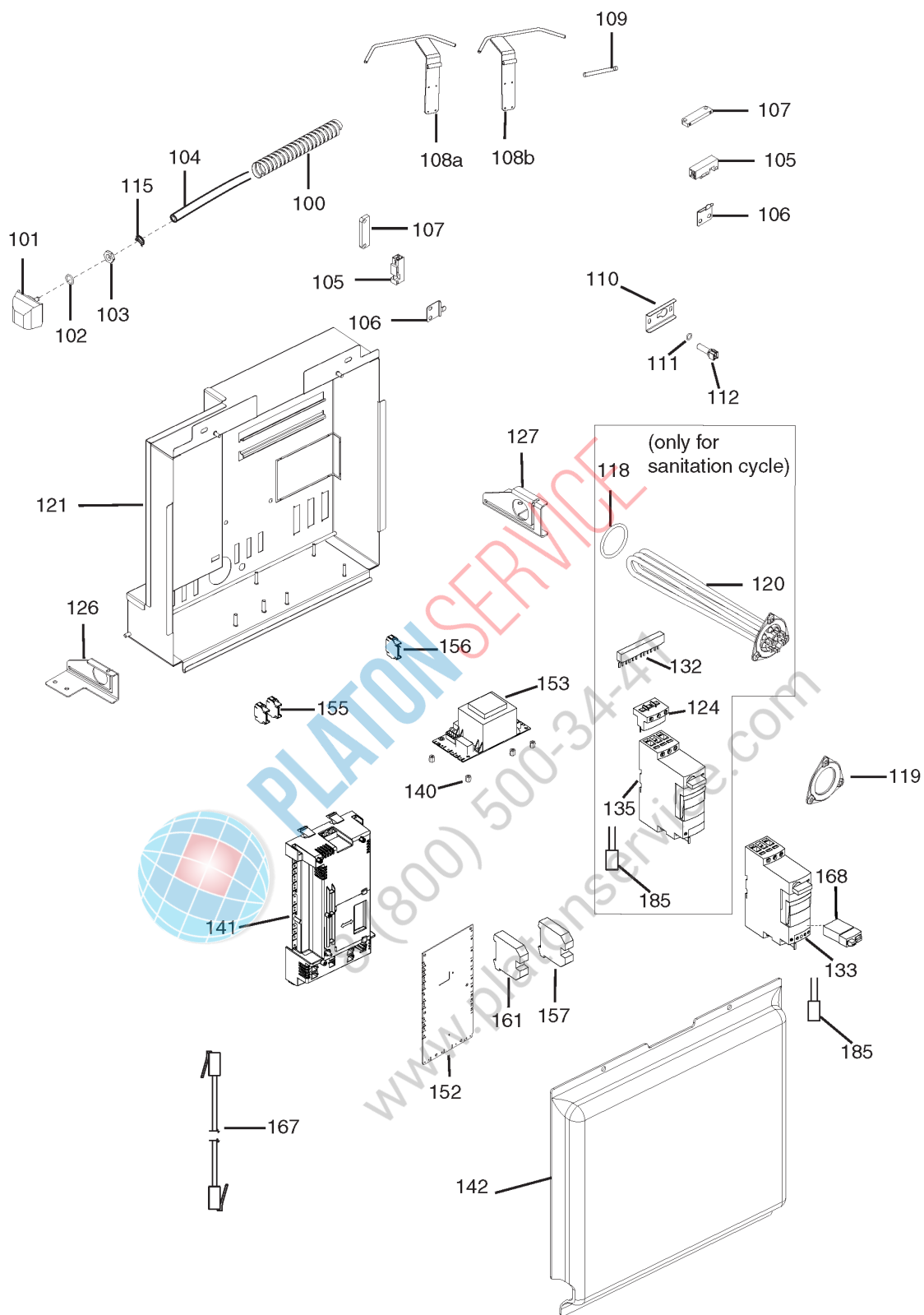

ill. 657001p9
 Prelavaggio da 22", Componenti elettrici / Prewash from 22", Electrical components

Da Ser.Nr./From Ser.nr.: 811 Page: 30 Ed.2008-09	Doc. Nr.: 595664900 (6-57001)
---	----------------------------------

??????	534304									
??????	595664900		???????? 30				Prewash from 22", Electrical components			
.		Alias		S			.			(Euro)
0100	0L1948	W00050701	0L1949	S			SHEATH			
0101	048308	542604901					AIR TRAP; FOR PRESSURE GAUGE			4,44
0102	068642	246035800					O-RING; ØI=15,54X2,62			1,02
0103	049268	544623800					HEX NUT; M14X1,5			1,80
0104	072393	W00537200					HOSE; Ø=4X7,4MM; L=500CM; PRESSURE SWITC			11,67
0105	049621	654600000				+	REED SWITCH			15,00
0106	0L3164	502698502		S			SENSOR SUPPORT			9,93
0107	0L2534	699605900		S			MAGNET; 63X18X7MM			24,16
0109	0L1449	514699000					AXIS; NEWRT			5,60
0110	0L0366	507683800		S			SUPPORT			3,44
0111	0L2303	543633Z00		S			O-RING; DIA.9,25X1,78			1,02
0112	049643	124294000					TEMPERATURE PROBE			9,76
0115	0L0082	518613000		S			CLAMP; DIA. 7,3-7,8MM			1,02
0118	0L2304	543633Y00		S			O-RING; DIA.56.52X5.33	only for sanitation cycle		4,54
0119	049928	507682600					FLANGE	Up to Ser. Nr.: 146		13,52
0119	0L2629	511620B00					FLANGE	From Ser. Nr.: 147		12,46
0120	0L1035	617623200	0L2759				HEATING ELEMENT; 10500W 230V	Only for sanitization cycle - Up to Ser. Nr.: 040		
0120	0L2242	617632100	0L2759				HEATING ELEMENT; 230V-10500W; RIGHT	Only for sanitization cycle		
0121	0L1707	850662B01					EL. COMPONENTS BOX; NEWRT	From Ser. Nr.: 041		143,10
0124	0L1013	639626600					TERMINAL BOARD; GV1-G09 63A	only for sanitation cycle		24,46
0126	0L1329	5026A0200					GUIDE; DX M600 NEWRT			21,11
0127	0L1316	5026A0300					GUIDE; SX M600 NEWRT			21,11
0132	0L1025	639626700					CONNECTION BAR	only for sanitation cycle		21,01
0133	0L1297	648613901		S			AUTOMATIC CIRCUIT BREAKER	0.35A÷1.4A		158,30
0135	0L1016	648614301		S	A		SWITCH; MOTOR START-UP UNIT	only for sanitation cycle - 8A÷32A		138,00
0140	088653	516807900		S			SPACER			2,23
0141	0L1738	673611100		S	A		PCB; MEC12R RT SLAVE; WITH BOX	Up to Ser: 4501		311,60
0141	0L3461	673612F02					PCB; WITH BOX; MEC 12 RT	From Ser: 4511		312,60
0142	0L1591	541615300					COVERING; ELECTRICAL BOX; 22"			59,28
0152	0L1739	699605200			A		PCB			46,08
0153	0L1408	624605901	0L2526				TRANSFORMER; 230V/24V 50VA NEWRT	Up to S.N.019		
0153	0L2191	624606301	0L2526				TRANSFORMER; CPL; WITH CARD	From S.N.020		
0155	0L1227	639627800					CONNECTOR; 8VIE R2.5			12,57
0156	0L1228	639627900					CONNECTOR; 10VIE R2.5			11,61
0157	0L1245	639628400					TERMINAL; BLU 4 MMQ			4,54
0161	0L1298	639628900					TERMINAL; BROWM WDU 4 MM			5,95

??????	534304									
??????	595664900		???????? 30					Prewash from 22", Electrical components		
.		Alias		S			.			(Euro)
0167	0L1396	639629000	0L2212					CABLE; RJ11 3600MM	Up to S.N.019	
0167	0L2212	639629J00		S				TELEPHONE CABLE; L=5000MM	From S.N.020	33,50
0168	0L1441	648615200		S	A			CONTACT; LUFC00 S204		42,93
0185	0L1771	694606300						RIF FILTER; 0.22MF 47OHM 250V		21,32
108a	0L1165	830645901						LEVER; START SX	For right machines	52,68
108b	0L1164	830645801						LEVER; START DX	For left machines	52,68



PLATON SERVICE

8 (800) 500-34-41

www.platonservice.com

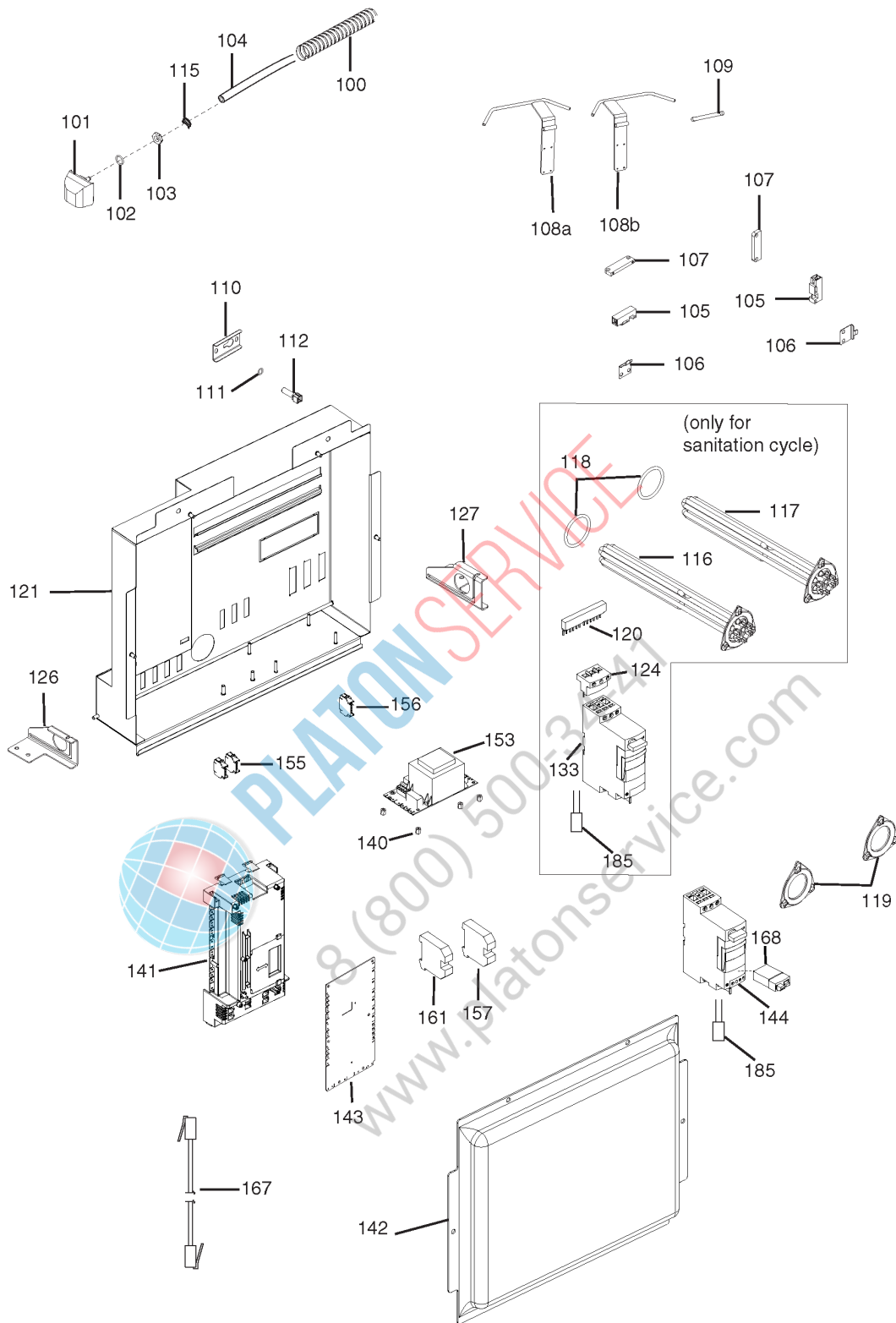

iii. 657001p10

Prelavaggio da 44", Componenti elettrici / Prewash from 44", Electrical components

Da Ser.Nr./From Ser.nr.: 811

Page: 32 Ed.2008-09

Doc. Nr.: 595664900

(6-57001)

??????		534304									
??????		595664900		???????? 32		Prewash from 44"		Electrical components			
.		Alias		S			.				(Euro)
0100	0L1948	W00050701	0L1949	S					SHEATH		
0101	048308	542604901							AIR TRAP; FOR PRESSURE GAUGE		4,44
0102	068642	246035800							O-RING; ØI=15,54X2,62		1,02
0103	049268	544623800							HEX NUT; M14X1,5		1,80
0104	072393	W00537200							HOSE; Ø=4X7,4MM; L=500CM; PRESSURE SWITC		11,67
0105	049621	654600000					+		REED SWITCH		15,00
0106	0L3164	502698502		S					SENSOR SUPPORT		9,93
0107	0L2534	699605900		S					MAGNET; 63X18X7MM		24,16
0109	0L1449	514699000							AXIS; NEWRT		5,60
0110	0L0366	507683800		S					SUPPORT		3,44
0111	0L2303	543633Z00		S					O-RING; DIA.9,25X1,78		1,02
0112	049643	124294000							TEMPERATURE PROBE		9,76
0115	0L0082	518613000		S					CLAMP; DIA. 7,3-7,8MM		1,02
0116	0L1039	617623500	0L2736						HEATING ELEMENT; 10500W	Up to Ser. Nr.: 040 - Only for sanitization cycle	
0116	0L2736	617632201		S					HEATING ELEMENT; 230V 10500W; LEFT	From Ser. Nr.: 041 - Only for sanitization cycle	91,25
0117	0L1006	617623000		S	A				HEATING ELEMENT; 6000W 230V	Only for sanitization cycle	80,19
0118	0L2304	543633Y00		S					O-RING; DIA.56.52X5.33	Only for sanitization cycle	4,54
0119	049928	507682600							FLANGE	Up Ser. Nr.: 146	13,52
0119	0L2629	511620B00							FLANGE	From Ser. Nr.: 147	12,46
0120	0L1025	639626700							CONNECTION BAR	Only for sanitization cycle	21,01
0121	0L1708	850662A01							EL. COMPONENTS BOX; NEWRT		152,30
0124	0L1013	639626600							TERMINAL BOARD; GV1-G09 63A	Only for sanitization cycle	24,46
0126	0L1329	5026A0200							GUIDE; DX M600 NEWRT		21,11
0127	0L1595	5026A5400							GUIDE; SX; ELECTRICAL BOX		24,26
0133	0L1016	648614301		S	A				SWITCH; MOTOR START-UP UNIT	8A÷32A - Only for sanitization cycle	138,00
0140	088653	516807900		S					SPACER		2,23
0141	0L1738	673611100		S	A				PCB; MEC12R RT SLAVE; WITH BOX	Up to Ser: 4501	311,60
0141	0L3461	673612F02							PCB; WITH BOX; MEC 12 RT	From Ser: 4511	312,60
0142	0L1202	541614700							COVERING; NEWRT		44,96
0143	0L1739	699605200			A				PCB		46,08
0144	0L1222	648614102		S					SWITCH; MOTOR START-UP UNIT	1.25A÷5A	158,30
0153	0L1408	624605901	0L2526						TRANSFORMER; 230V/24V 50VA NEWRT	Up to S.N.019	
0153	0L2191	624606301	0L2526						TRANSFORMER; CPL; WITH CARD	From S.N.020	
0155	0L1227	639627800							CONNECTOR; 8VIE R2.5		12,57
0156	0L1228	639627900							CONNECTOR; 10VIE R2.5		11,61
0157	0L1245	639628400							TERMINAL; BLU 4 MMQ		4,54

??????	534304									
??????	595664900		???????? 32						Prewash from 44", Electrical components	
.		Alias		S			.			(Euro)
0161	0L1298	639628900							TERMINAL; BROWM WDU 4 MM	5,95
0167	0L1396	639629000	0L2212						CABLE; RJ11 3600MM	Up to S.N.019
0167	0L2212	639629J00		S					TELEPHONE CABLE; L=5000MM	From S.N.020
0168	0L1441	648615200		S	A				CONTACT; LUFC00 S204	42,93
0185	0L1771	694606300							RIF FILTER; 0.22MF 47OHM 250V	21,32
108a	0L1165	830645901							LEVER; START SX	For right machines
108b	0L1164	830645801							LEVER; START DX	For left machines



PLATON SERVICE

8 (800) 500-34-41

www.platonservice.com

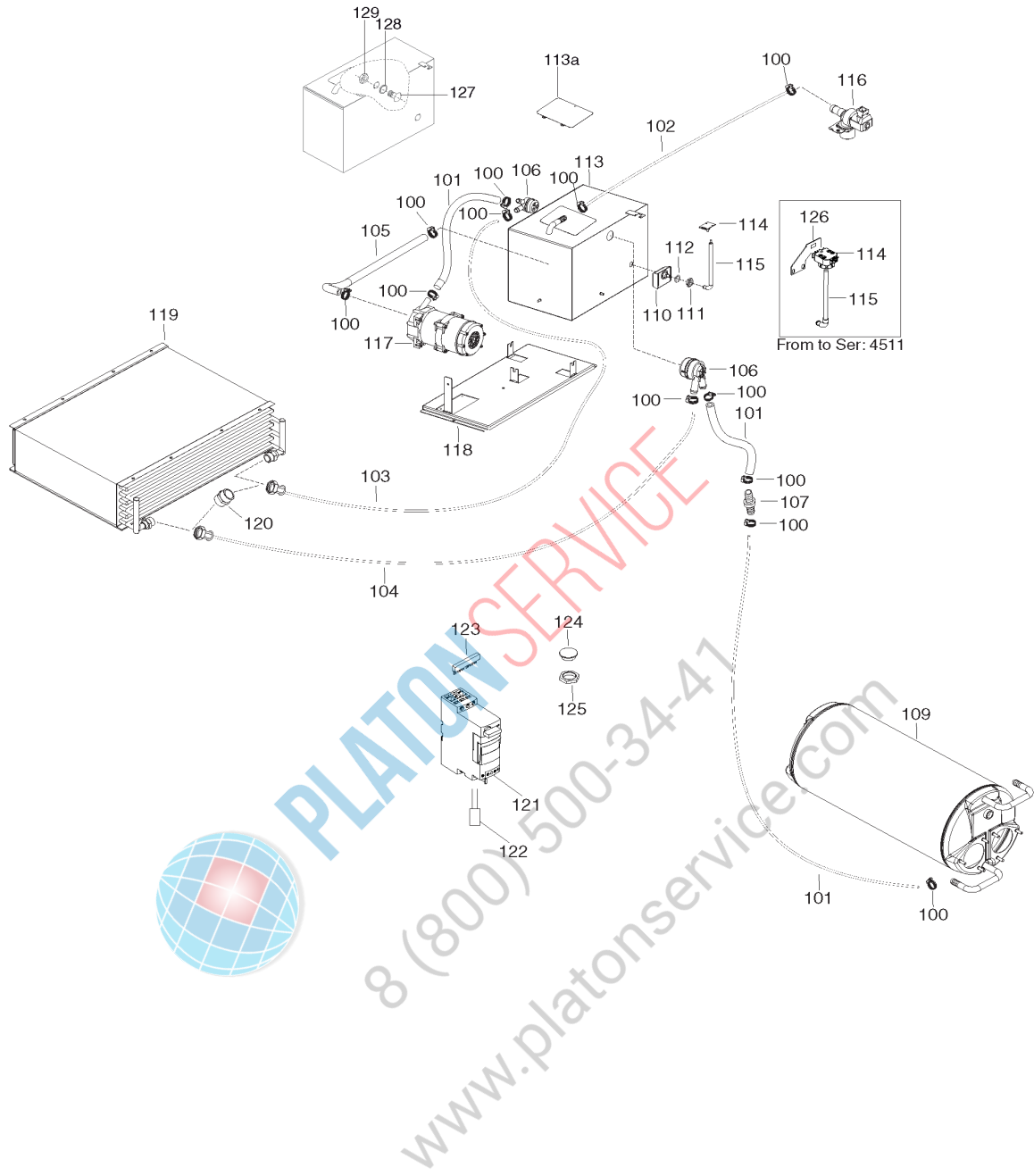

ill. 657001p11
Kit Air gap (Only for Middle East version - WTCS140XXO/ WTCS180XXO)

Da Ser.Nr./From Ser.nr.: 811 Page: 35 Ed.2015-09	Doc. Nr.: 595664900 (6-57001)
---	---

??????	534304										
??????	595664900	???????? 35	Kit Air gap (Only for Middle East version - WTCS140XXO/ WTCS180XXO)								
.		Alias		S			.			(Euro)	
0100	048126	518609801							CLIP; 13-20	1,58	
0101	048531	140066039							RUBBER HOSE; ØI=12MM;ØE=19,5MM;BY METER	9,55	
0102	049379	140066047	0L3641						HOSE; WRC, 1PC=1130MM	22,23	
0103	0L2047	830654T00							FEEDER HOSE	23,14	
0104	0L2048	830654U00							DRAIN HOSE	25,48	
0105	0L2045	544685B00							PUMP SUCTION PIPE	27,10	
0106	0L1892	544685800		S					NONRETURN VALVE; HIGH TEMPERATURE	18,09	
0107	0L2049	5146A2F00							SHUTTER; 4 L/MIN	Not for RTC250/WTC250	46,08
0107	0L2050	5146a2G00							SHUTTER; 5 L/MIN	For RTC250/WTC250	46,08
0109	0L1766	850662G00		S					BOILER; ASSY; NEWRT	Up to Ser.Nr.: 851	245,60
0109	0L1766	850662G01		S					BOILER; ASSY; NEWRT	From Ser.Nr.: 022 - Not for Middle East	245,60
0109	0L1959	850663500	0L1766						BOILER; ASSY; COMPACT EUROPA NEWRT	From Ser.Nr.: 852 - Up to Ser.Nr.: 021 - Not for Middle East	
0109	0L1983	850663L01							BOILER; ASSY; COMPACT EUROPA AISI 316L	For Middle East	624,00
0110	048308	542604901							AIR TRAP; FOR PRESSURE GAUGE		4,44
0111	049268	544623800							HEX NUT; M14X1,5		1,80
0112	068642	246035800							O-RING; ØI=15,54X2,62		1,02
0113	0L2046	509612700	0L2282						SHEET METAL	Up to Ser.Nr.: 020	
0113	0L2274	850663Y00	0L2282				+		AIR GAP	From Ser.Nr.: 021	
0113	0L2274	850663Y00	0L2282				+		AIR GAP	Up to Ser.Nr.: 4501	
0113	0L2274	850663Y01	0L2282				+		AIR GAP	From Ser.Nr.: 4511	
0114	0L1132	673608302		S	A				PCB; PRESSUR SENSOR	Up to Ser:4501	58,67
0114	0L2845	673611M00		S					ANALOGIC SENSOR	From Ser:4511	17,73
0115	0L1909	544685A00		S					AIR TRAP TUBE	Up to Ser.Nr.: 4501	16,36
0115	0L3088	544688D00							PRESSURE SWITCH HOSE	From Ser.Nr.: 4511	3,91
0116	0L1198	696617400	0L3449						SOLENOID VALVE; 20L/MIN 24V 50-60HZ	Up to Ser.Nr.: 019	17,97
0116	0L2327	696618400	0L3449		A				WATER SOLENOID VALVE; 20L/ MIN 24V 50-60H	From Ser.Nr.: 020	20,00
0117	0L1384	611634600		S	A				PUMP; 400V 50HZ 0.45HP		217,20
0118	0L2044	509612600							SUPPORT; FOR AIR-GAP		50,34
0119	0L1730	511620800	0L3573						HEAT EXCHANGER; NEWRT	Up to Ser.: 5141	
0119	0L3573	511621200		S					HEAT EXCHANGER; FOR ESD	From Ser.: 5151	680,00
0120	072457	W00526300		S					NIPPLE		10,04
0121	0L1297	648613901		S					AUTOMATIC CIRCUIT BREAKER		158,30
0122	0L1771	694606300							RIF FILTER; 0.22MF 47OHM 250V	Up to Ser: 4501	21,32
0122	0L3459	694606300							RIF FILTER; 0,22µF 47OHM 250V	From Ser: 4511	9,45
0123	0L1025	639626700							CONNECTION BAR		21,01

??????	534304								
??????	595664900	???????? 35	Kit Air gap (Only for Middle East version - WTCS140XXO/ WTCS180XXO)						
.		Alias		S			.		(Euro)
0124	0L1148	5146A0600			D			PLUG; 3/4"	84,25
0125	0E5056	W00525500		S				NUT	12,13
0126	0L3302	5056A2M01						PRESSURE SWITCH SUPPORT	From to Ser:4511
0127	0L3493	5146A8100						PLUG; 1/4" GAS	From to Ser: 4511
0128	0L2305	543633X00						O-RING; DIA.2,62X15,54	From to Ser: 4511
0129	0H2610	W00525300						NUT	From to Ser: 4511
113a	0L2281	5026B3100				+		LID	From Ser.Nr.: 021



PLATON SERVICE

8 (800) 500-34-47

www.platonservice.com